

4 Burner Gas Grill BBQ

Model# HSGT400-B1

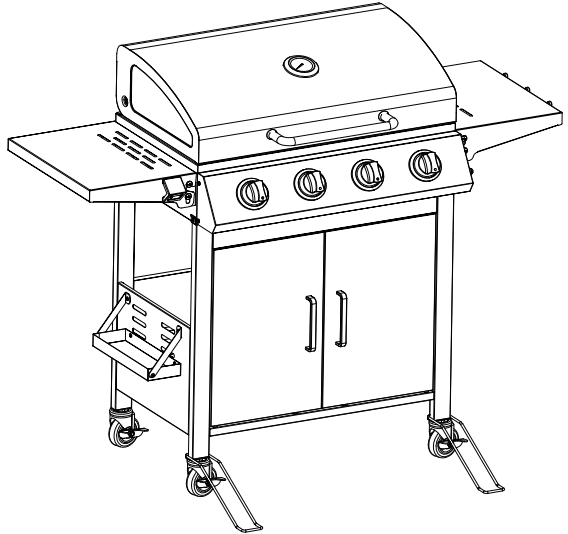

Assembler/Installer: This manual contains important information needed for the proper assembly and safe use of this equipment. Read and follow all warnings and instructions before assembling and using this appliance. **Leave the instructions with the consumer.**

Consumer/User: Follow all warnings and instructions when using this appliance.
Retain these instructions for future reference.

⚠ DANGER

If you smell gas:

1. Shut off gas to the appliance.
2. Extinguish any open flame.
3. Do not open the grill lid.
4. If odor continues, keep away from the appliance and immediately call your gas supplier or your local fire department.

⚠ WARNING

1. Do not store or use gasoline or other flammable liquids or vapors in the vicinity of this or any other appliance.
2. An LP (liquid propane) cylinder not connected for use shall not be stored in the vicinity of this or any other appliance.
3. This grill is for outdoor use only and shall not be used in a building, garage, under overhangs or any other enclosed area.
4. Do not leave a lit grill unattended. Keep children and pets away from the grill at all times.



SAFETY INFORMATION

Please read and understand this entire manual before attempting to assemble, operate or install the product.

DANGER

- Do not use in an explosive atmosphere. Keep grill area clean and free from combustible materials, gasoline and other flammable vapors and liquids.



CALIFORNIA PROPOSITION 65

Fuels used in gas or oil fired appliances and the products of combustion of such fuels contain chemicals known to the State of California to cause cancer, birth defects or other reproductive harm. This product contains chemicals, including lead and lead compounds, known to the State of California to cause cancer, birth defects or other reproductive harm. ***Wash hands after handling parts or before food preparation.***

CAUTION

- Never use charcoal or lighter fluid with the grill.
- Do not use gasoline, kerosene or alcohol for lighting.
- The LP gas cylinder used with this appliance must be:
 - (a) Constructed and marked in accordance with the Specifications for LP-Gas Cylinders of the U.S. Department of Transportation (D.O.T.) or the National Standard of Canada, CAN/CSA-B339, Cylinders, Spheres and Tubes for Transportation of Dangerous Goods; and Commission, as applicable; and
 - (b) Provided with a listed overfilling prevention device.
 - (c) Provided with a cylinder connection device compatible with the connector for outdoor cooking appliances. This grill is not intended to be used in or installed on recreational vehicles and/or boats.
- Never keep a filled container in a hot car or car trunk. Heat will cause the gas pressure to increase, which may open the relief valve and allow gas to escape.
- Always open grill lid slowly and carefully as heat and steam trapped within the grill can burn you severely.

SAFETY INFORMATION

WARNING

• Do not place the grill under overhead combustible construction or awnings. Maintain a minimum clearance of 36 inches (914 mm) from the sides and back of the grill to any combustible construction.

NOTE: The installation must conform with local codes or, in the absence of local codes, with either the National Fuel Gas Code, ANSI Z223.1/NFPA 54, Natural Gas and Propane Installation Code, CSA B149.1, or Propane Storage and Handling Code, B149.2.

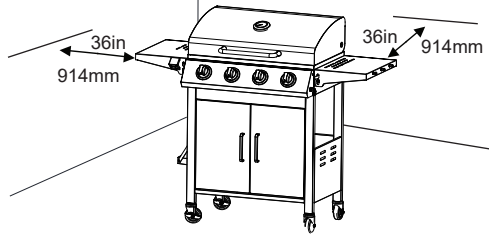







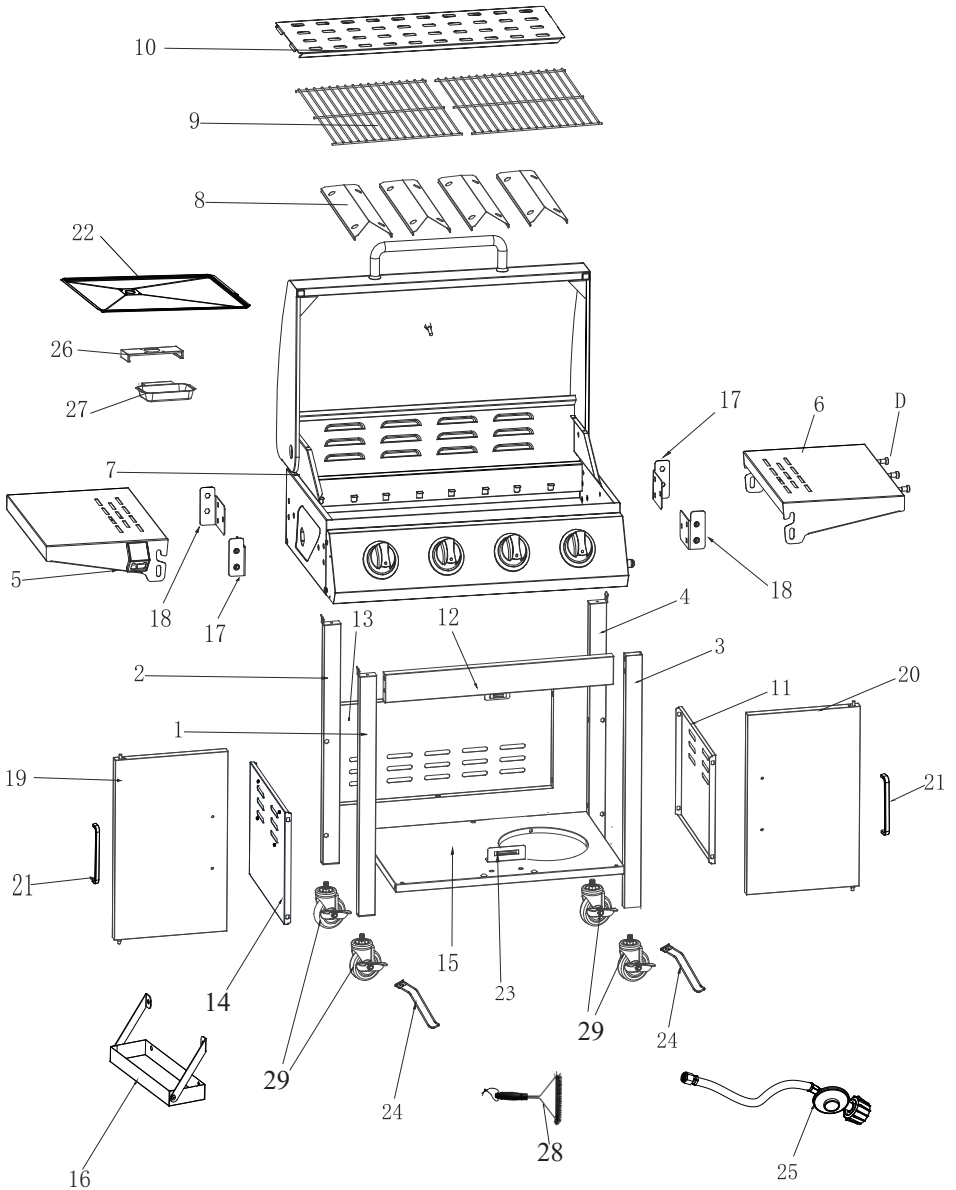



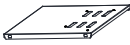

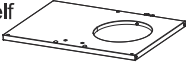



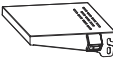







CAUTION

- Do not store or use gasoline or other flammable liquids or vapors in the vicinity of this or any other appliance.
- An LP cylinder not connected for use shall not be stored in the vicinity of this or any other appliance.
- This grill is for use with propane gas only (propane cylinder not included).
- Never attempt to attach this grill to the self-contained propane system of a boat, camper trailer, motor home or house.
- Do not attempt to move the grill while it is lit or when it is hot. The casters should be locked when not moving the grill.
- Do not use the grill unless it is completely assembled and all parts are securely fastened and tightened.
- Keep all combustible items and surfaces at least 36 inches (914 mm) away from the grill at all times.
- Do not touch metal parts of grill until it has completely cooled (about 45 minutes) to avoid burns, unless you are wearing protective gear (pot holders, gloves, BBQ mittens, etc...).
- Do not alter this grill in any manner.
- Clean and inspect the hose before each use. If there is evidence of abrasion, wear, cuts, or leaks, the hose must be replaced prior to operating the appliance. The replacement hose assembly will be that which is specified by the manufacturer, listed in the repair parts list in this manual.
- Move gas hoses as far away as possible from hot surfaces and dripping hot grease.
- Keep the grill's valve compartment, burners and circulating air passages clean. Inspect the grill before each use. Do not obstruct the flow of gas or ventilation air.
- The use of alcohol, prescription or non-prescription drugs may impair the operator's ability to properly assemble or safely operate the grill.
- **Do not leave a lit grill unattended. Keep children and pets away from the grill at all times.**
- Do not place this grill on any type of tabletop surface. The grill should be placed on a flat and level surface.
- Do not use the grill in high winds.



EXPLODED DIAGRAM

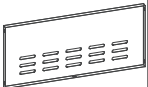







PACKAGE CONTENTS

NO	DESCRIPTION	PCS	NO	DESCRIPTION	PCS
1	Leg(#1) 	1	14	Left Cart Side Panel 	1
2	Leg(#2) 	1	15	Bottom Shelf 	1
3	Leg(#3) 	1	16	Spice Holder 	1
4	Leg(#4) 	1	17	Side Table Support A 	2
5	Left Side Table 	1	18	Side Table Support B 	2
6	Right Side Table 	1	19	Left Door 	1
7	Grill Body 	1	20	Right Door 	1
8	Heat Tent 	4	21	Door Handle 	2
9	Cooking Grate 	2	22	Grease Pan 	1
10	Warming Rack 	1	23	Door Stopper 	1
11	Right Cart Side Panel 	1	24	Anti-tip Bracket 	2
12	Upper Door Brace 	1	25	Regulator 	1
13	Cart Rear Panel 	1	26	Grease Box Bracket 	1

PACKAGE CONTENTS

NO	DESCRIPTION	PCS	NO	DESCRIPTION	PCS
27	Grease Box 	1	29	Locking Caster 	4
28	Wire Brush 	1			

HARDWARE CONTENTS

A	M6x10 mm Bolt		x43
B	M6 Leveling Bolt		x8
C	M4x8 mm Bolt		x4
D	Hook		x3
E	M4x8 Waterproof Bolt		x4
F	M4 Nut		x4

ASSEMBLY INSTRUCTIONS

Step 1

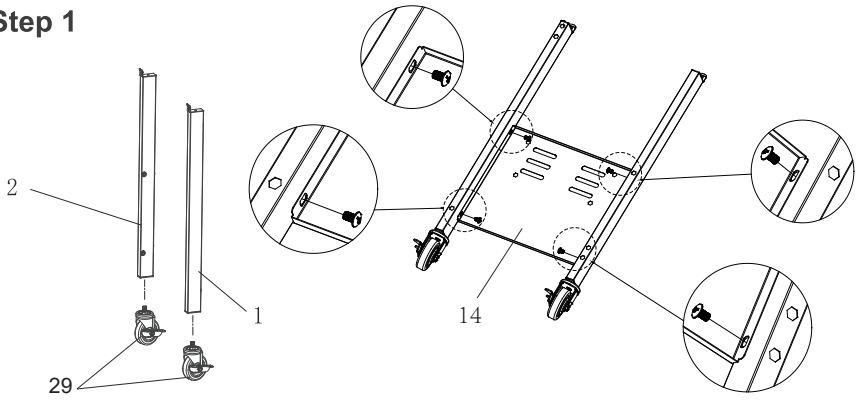

A | M6 x 10mm |  | x 4

Step 2

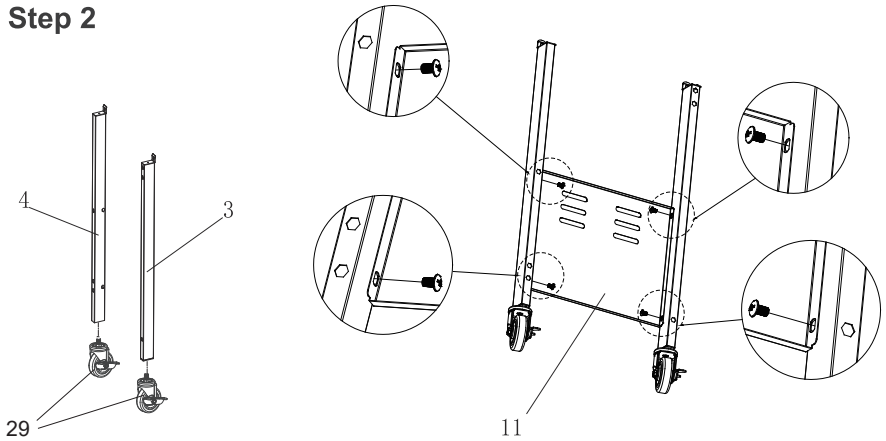

A | M6 x 10mm |  | x 4

Step 3

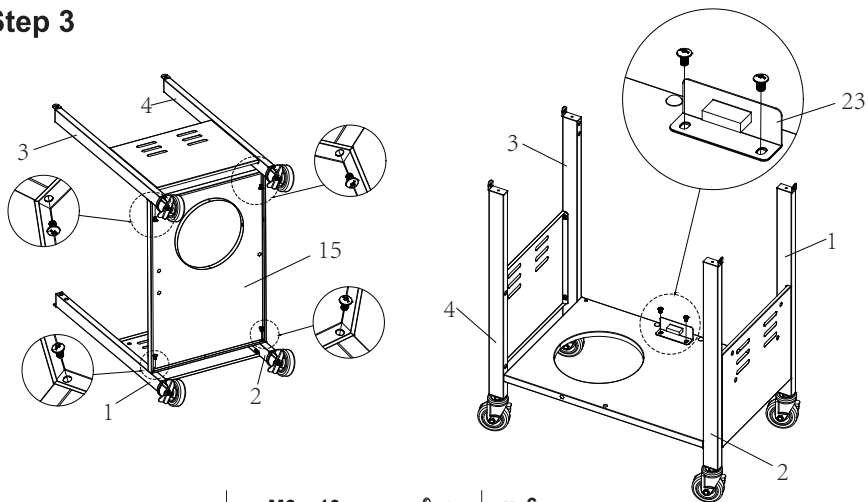

Step 4

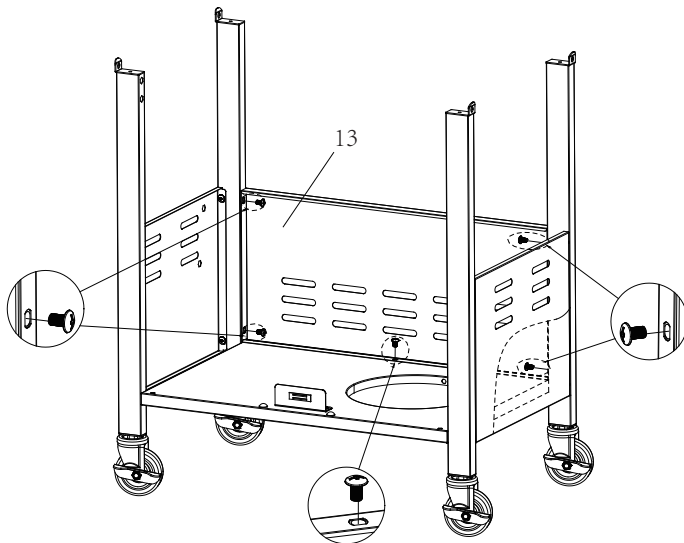

Step 5

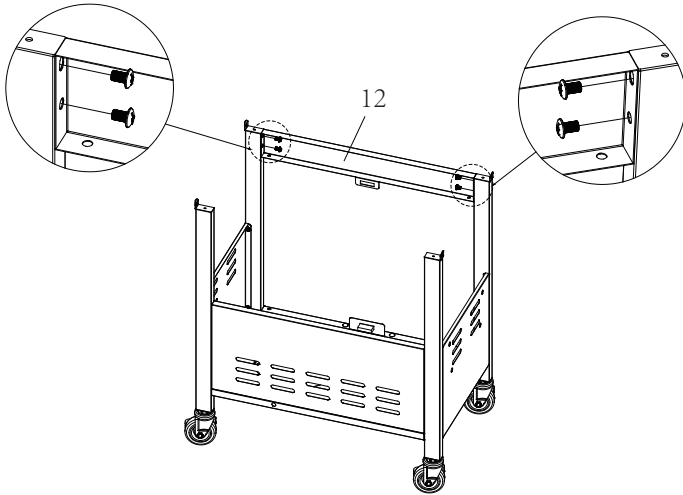

A | M6 x 10mm  | x 4

Step 6

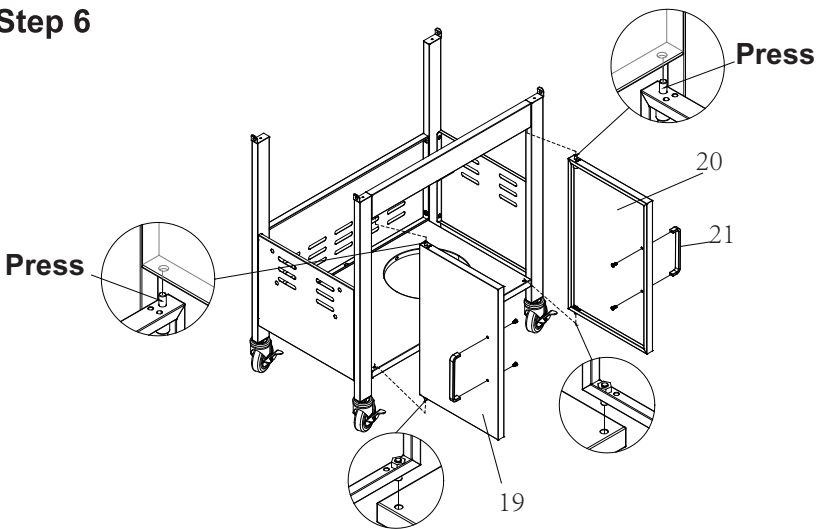

C | M4x 8 mm  | x 4

Step 7

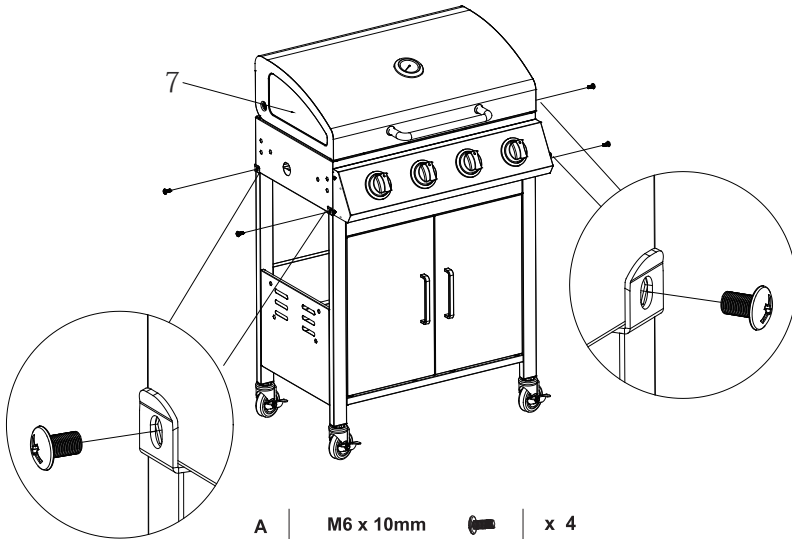

Step 8

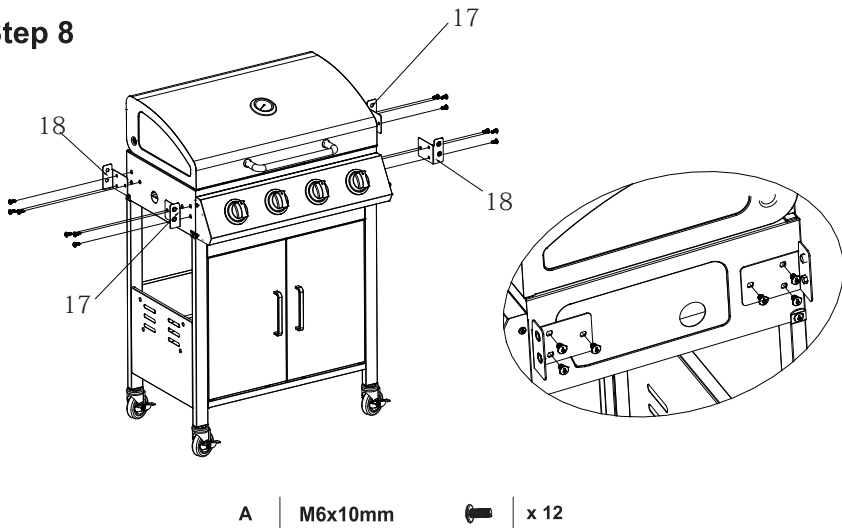

Step 9

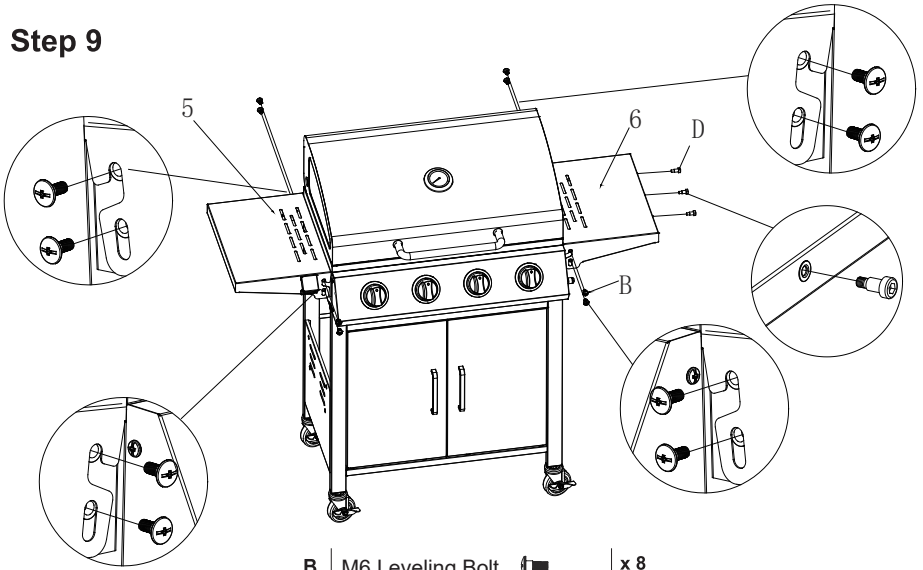

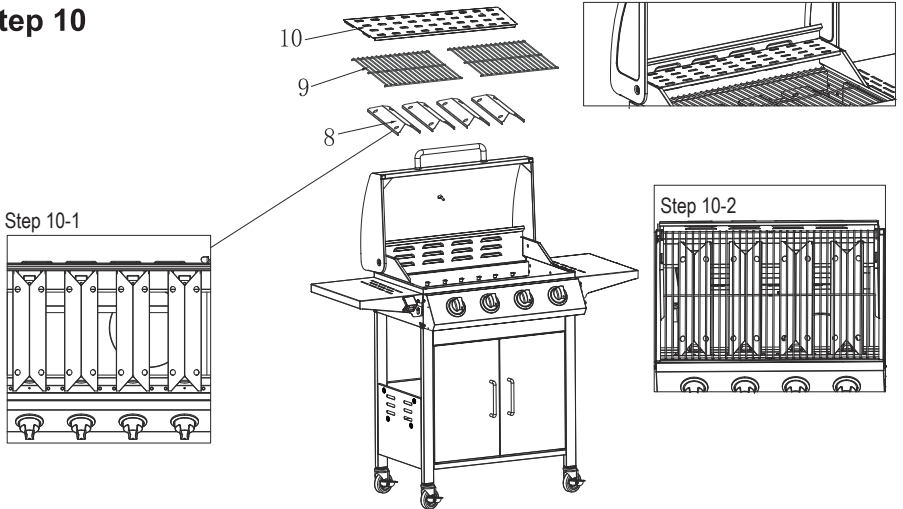

B	M6 Leveling Bolt		x 8
D	Hook		x 3

Step 10

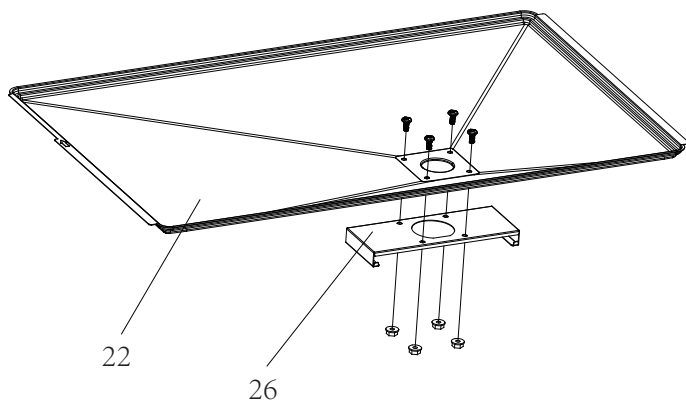

Step 11



E	M4x8 Waterproof		x 4
F	M4 Nut		x 4

Step 12

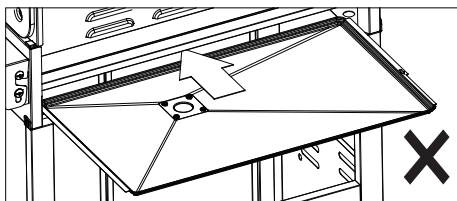
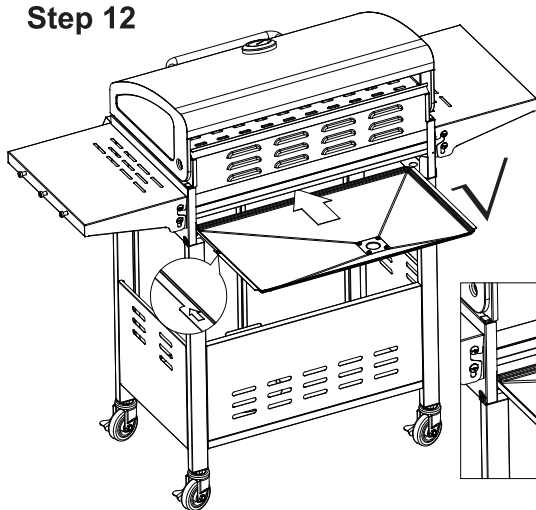

Step 13

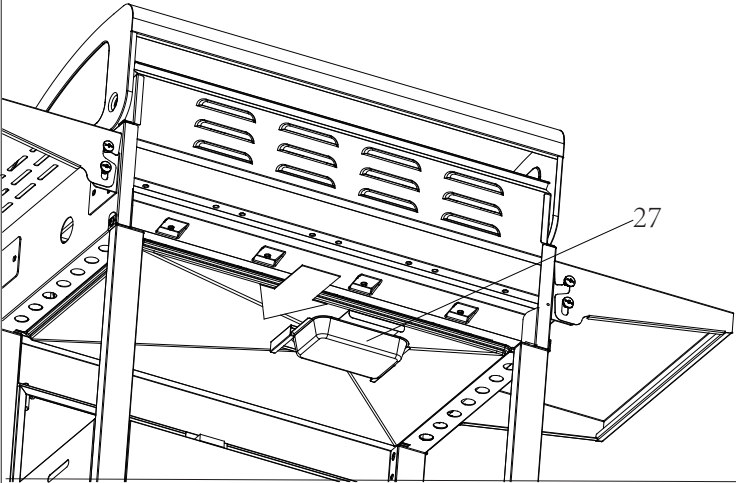

Step 14

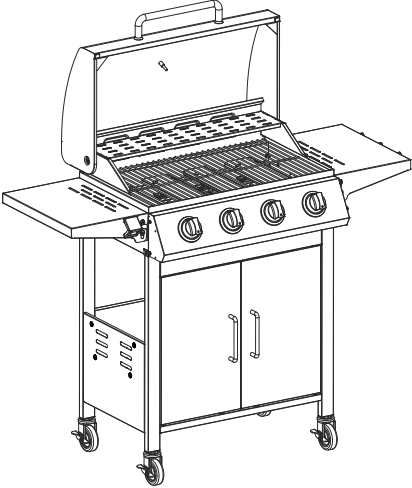

Step 15

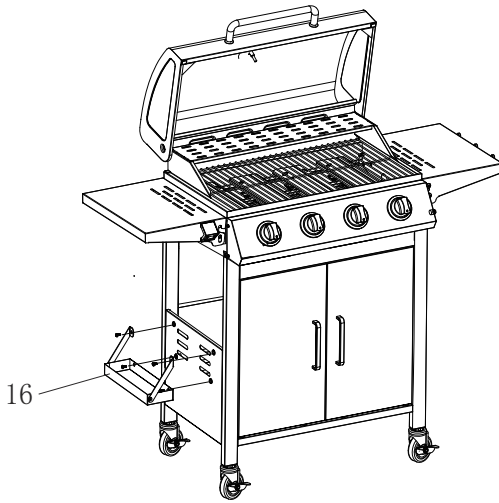

A | M6 x 10mm  | x 4

Step 16

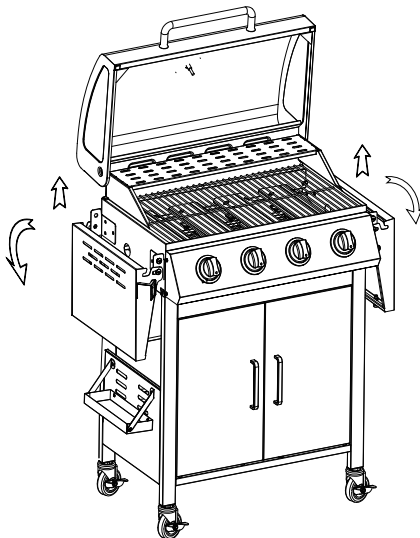

Step 17

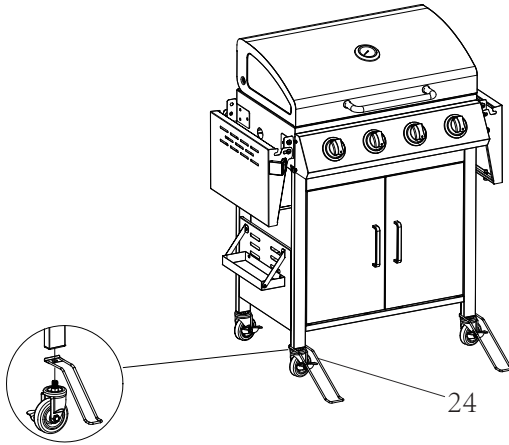

Install part #24 when using on uneven surfaces

Step 18

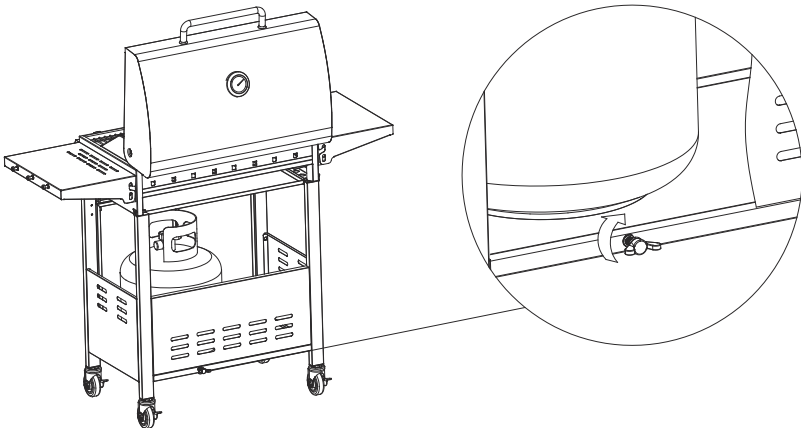

OPERATION INSTRUCTIONS

CHECKING FOR LEAKS

After all connections are made, check all connections and fittings on the LP gas tank valve, gas hose and regulator for leaks with a water and soap solution.

To prevent fire or explosion while testing for a leak:

- Always perform leak test prior to lighting the grill.
- Do not smoke while testing for a leak.
- Always perform leak tests outdoors in a well-ventilated area.
- Do not use any source of flame while testing for leaks.
- Do not use the grill until any and all leaks are corrected.
- If you are unable to correct a leak, disconnect the propane supply and call a gas appliance service dealer.

PERFORM LEAK TEST

- Prepare leak test solution by combining 1 part liquid dish soap with 3 parts water. Total solution required is approximately 2 - 3 ounces (70 - 90 ml). Place the leak test solution in a spray bottle.
- Ensure all control knobs are in the ● OFF position.
- Connect the gas hose to the gas supply.
- Open the LP gas tank valve.
- Spray leak test solution on all gas-carrying connections and fittings. The presence of bubbles in areas of the applied test solution indicates a gas leak. If leaks are detected or you smell or hear gas, shut off the gas supply valve immediately and repair or replace the defective part. Do not use the grill until all leaks are corrected.

⚠ CAUTION

Only use the hose assembly provided! If a replacement is necessary, please call our customer service center. Do not use replacement parts that are not intended for this grill.

⚠ WARNING

ALL INSTRUCTIONS AND SAFEGUARDS ON THIS PAGE MUST BE FOLLOWED TO PREVENT FIRE, DAMAGE AND/OR INJURY.

OPERATION INSTRUCTIONS

CONNECTING GAS CYLINDER

The propane gas supply cylinder to be used must be constructed and marked in accordance with the Specifications for LP Gas Cylinders of the U.S. Department of Transportation (D.O.T.) or the National Standard of Canada, CAN/CSA-B339, Cylinders, Spheres and Tubes for Transportation of Dangerous Goods; and Commission, as applicable; and Provided with a listed overfilling prevention device.

Use only 20-pound cylinders (height: 18.11 inches, tank diameter: 9.84 inches, foot diameter: 8.03 inches) equipped with a cylinder connection device compatible with the connection for outdoor cooking appliances.

The cylinder must include a collar to protect the cylinder valve. The gas cylinder should not be dropped or handled roughly!

If the appliance is not in use, the gas cylinder must be disconnected. Storage of an appliance indoors is permissible ONLY if the cylinder is disconnected and removed from the appliance. Cylinders must be stored outdoors out of the reach of children and must not be stored in a building, garage or any other enclosed area. Your cylinder must never be stored where temperatures can reach over 125°F.

Place dust cap on cylinder valve outlet whenever the cylinder is not in use. Only install the type of dust cap on the cylinder valve outlet that is provided with the cylinder valve. Other types of caps or plugs may result in leakage of propane.

Before connection, be sure that there is no debris caught in the outlet of the gas cylinder, outlet of the regulator valve or in the outlet of the burner and burner ports. Connect regulator valve and hand-tighten firmly. Keep the propane cylinder valve closed and disconnect the propane cylinder from the regulator valve when the grill is not in use.

DO NOT obstruct the flow of combustion air and ventilation air to the grill. The propane cylinder must be arranged for vapor withdrawal and equipped with a listed overfilling prevention device. Please use the proper cylinder orientation to provide vapor withdrawal. NOTE: The cylinder must be fully upright for the cylinder to have vapor withdrawal only.

▲ CAUTION

- a. Do not store a spare LP-gas cylinder under or near this appliance.**
- b. Never fill the cylinder beyond 80 percent full.**
- c. If the information in (a) and (b) is not followed exactly, a fire may result, causing death or serious injury.**

OPERATION INSTRUCTIONS

NOTE: Other cylinders may be acceptable for use with this appliance provided they are compatible with the appliance nesting hole and retention means. Refer to Step 15 of the Assembly Instructions for correct cylinder to cylinder holder connection.

⚠ WARNING

ALL INSTRUCTIONS AND SAFEGUARDS ON THIS PAGE MUST BE FOLLOWED TO PREVENT FIRE, DAMAGE AND/OR INJURY.

CONNECTING THE LP TANK

1. The knob on the LP tank must be closed. Make sure that the knob is turned ↻ clockwise to a full stop. The cylinder supply system must be arranged for vapor withdrawal.
2. Check that the control knob on the control unit is turned off.
3. Remove the protective cap from the LP tank valve and coupling nut.
4. Hold the regulator in one hand and insert the nipple into the valve outlet. Be sure the nipple is centered in the valve outlet. The coupling nut connects to the large outside threads on the valve outlet. Use care — do not cross thread the connection.
5. Hand-tighten the coupling nut ↻ clockwise until it comes to a full stop. Firmly tighten by hand only. Do not use tools.

To Disconnect: Fully close the tank valve by turning ↻ clockwise. Turn the coupling nut ↻ counterclockwise until the regulator assembly disengages.

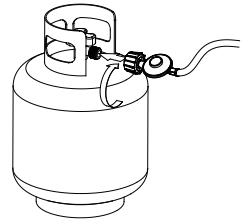
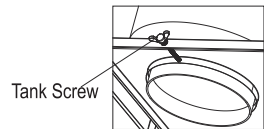
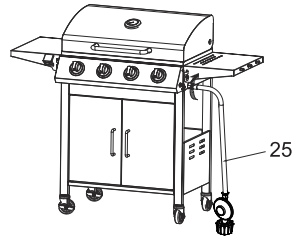

⚠ WARNING

In the connection process, make sure:

- the regulator inlet connector mates with the cylinder valve outlet properly, safely and firmly.
- the LP gas hose does not come in contact or remain in contact with the firebox.

OPERATION INSTRUCTIONS

FIRE AND EXPLOSION HAZARD

- Immediately evacuate the area and ensure the safety of all bystanders.
- If it is safe to do so, shut off the gas supply at the cylinder valve.
- Cool the gas cylinder by applying water from a safe distance.
- Be aware of the risk of re-ignition or explosion.

Lighting The Grill

Before first use:

Remove all hangings or plastic straps, if present. Before you cook on your new gas grill, it is important to clean your grill with heat. To do this, operate the grill for approximately 15 minutes with the lid closed and the control knob in the highest position. This will clean the internal parts by burning off any residue and odor from the manufacturing process.

⚠ CAUTION

If the flame extinguishes accidentally during ignition or operation, immediately TURN OFF the cylinder valve and then TURN OFF the control knob.

⚠ WARNING

Do not lean over grill when lighting. Read instructions before lighting.

1. Check that the control knobs are in the ● OFF position.
 2. Fully open the cylinder valve by turning the knob ↺ counterclockwise.
 3. Open lid during lighting.
 4. Push igniter down 3 to 4 seconds while turning right side control knob to the HIGH position. The burner should ignite.
 5. Repeat for all other burners.
- If ignition does not take place within 5 seconds, immediately turn the control knob to the ● OFF position. Wait 5 minutes and repeat step 4 above or refer to match lighting instructions below.

If the burner still does not light, check that there is gas in the cylinder and follow the match lighting instructions.

OPERATION INSTRUCTIONS

FLAME THROWER IGNITION

This BBQ is equipped with automatic ignition, as indicated on the front fascia of the BBQ frame. It works by throwing a flame to the side of the burner to light. Push the knob in and turn anticlockwise to the high position. You should hear and feel a click from the knob. Hold the knob in until the burner ignites. If the burner does not light on the first attempt, return the knob to the "OFF" position and try a couple more times. If the burner still does not light, wait a few minutes to allow the gas to disperse before trying again.



MANUAL IGNITION

1. Insert a long match or gas lighter (not provided) through the cooking grate and position it near the
2. Keep your hand below the bottom of the burner while doing this.
3. Turn the burner on.
4. You should see the burner alight.
5. Repeat to light the other burners.

CAUTION

Make sure all burner controls are off, except for the burner being lit and the burners that have been lit.

SHUTDOWN INSTRUCTIONS

1. Turn control knobs  clockwise to the ● OFF position.
2. Close valve at tank fully by turning  clockwise.
3. Close lid.

Turn off LP supply at cylinder when appliance is not in use.

CARE AND MAINTENANCE

Cooking Grates

The best time to 'burn-off' the cooking grates is after every use (approx. 15 minutes). The grill is already hot from cooking thus requiring less fuel to obtain the necessary temperature for 'burn-off'.

To 'burn off' or heat clean your grill, turn the burners to the highest position and run for 15 minutes with the lid closed. Then turn off the burners and use a wire brush to clean excess food residue from the grates.

The porcelain grates have an enamel finish (similar to glass) and should be handled with care not to chip.

⚠ CAUTION

Ensure the grill is cool before cleaning and conducting maintenance and with the gas supply turned off at the manual gas shutoff valve.

CARE AND MAINTENANCE

Recommended Cleaning Supplies

Mild liquid dish soap, warm water, nylon cleaning pad, wire brush

DO NOT use cleaners that contain acid, mineral spirits or any abrasive substance.

Outside Surfaces

It is recommended to use only mild dish soap and hot water to clean grill and grill parts.

Rinse with warm water.

Inside Bottom Pan of Grill Body

To avoid flare-ups, the bottom pan of the cooking box should be kept clean regularly.

Remove residue using a brush, scraper and/or cleaning pad. Wash with mild dish soap and warm water. Rinse with warm water. Avoid water splashing into venturi tubes of burners.

Heat Tents

Clean residue with wire brush and wash with mild dish soap and warm water. Rinse with warm water.

Checking The Flame

For maximum fuel efficiency and cooking performance, flame should be a blue-yellow color and be between 1- 2 inches high.

To check the flame, view the flame through the holes in the two sides of the firebox as shown.

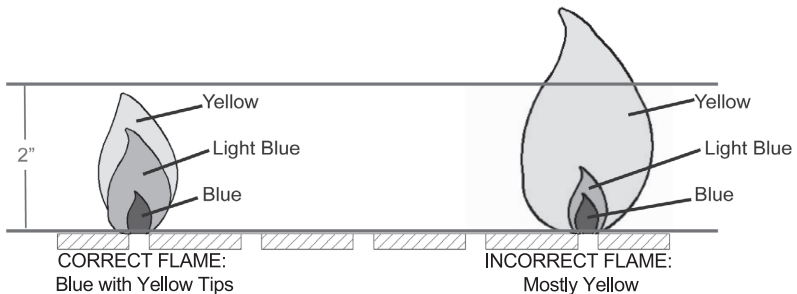

You should periodically inspect the burners for blockages. To do this, remove and inspect them. If any holes are clogged, tap the burner lightly on a hard surface to remove any residue. Use a wire brush to clear the holes. After cleaning, lightly coat the burners with oil to prevent rust.

CARE AND MAINTENANCE

BURNER MAINTENANCE

To reduce the chance of "FLASH-BACK", the procedure below should be followed at least once a month in late summer or early fall when spiders are most active or when your BBQ has not been used for a period of time.

1. Turn all burner valves to the full OFF position.
2. Turn the gas cylinder valve (clockwise) to the full OFF position.
3. Detach the regulator assembly from the gas cylinder.
4. Remove all burners from the bottom of the BBQ. Use a screwdriver or needle nose pliers.
5. Carefully lift each burner up and away from the gas valve orifice.
6. Refer to figure below and perform one of these three cleaning methods.

Bend a stiff wire, (a lightweight coat hanger works well) into a small hook as shown below, Run the hook through the burner tube and inside the burner several times to remove any debris.

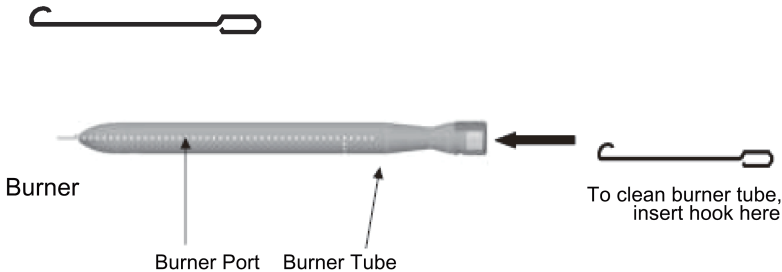

Method 1: Use a flexible-handle brush. Run the brush through the burner tube and inside the burner several times, removing any debris.
Method 2: Use an air hose to force air through each burner tube. The forced air should pass debris or obstructions through the burner and out the ports.

1. Regardless of which burner cleaning procedure you use, we recommend you also complete the following steps to help prolong burner life.
2. Use a wire brush to clean the entire outer surface of each burner until free of food residue or dirt.
3. Clean clogged ports with wire, such as an open paper clip.

Inspect each burner after installation, check to ensure that the gas valve orifices are correctly placed inside the end of the burner tubes.