

# Assembly Instruction

## OUTDOOR ROCKING CHAIR SET

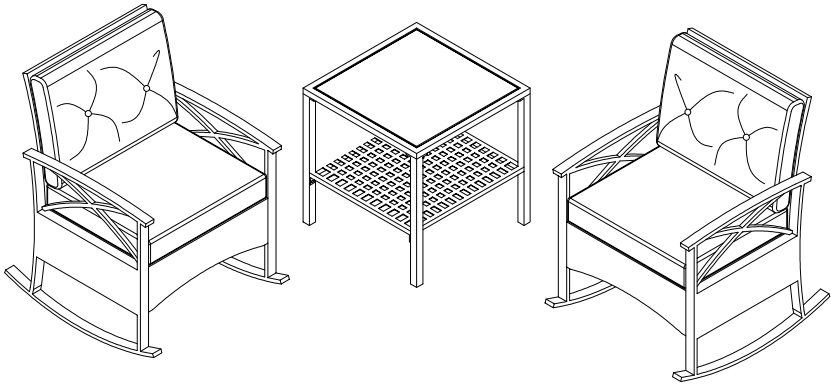

If you have any questions, please reach out to us at [info@serviceprohelp.com](mailto:info@serviceprohelp.com).

# Exploded View

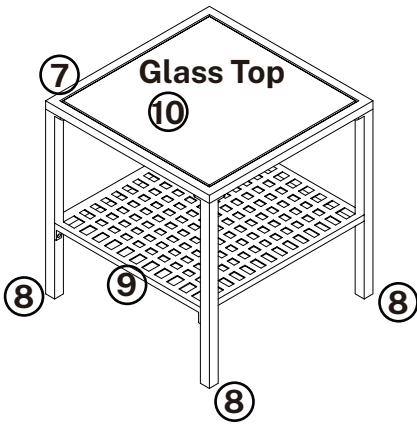

**X1**

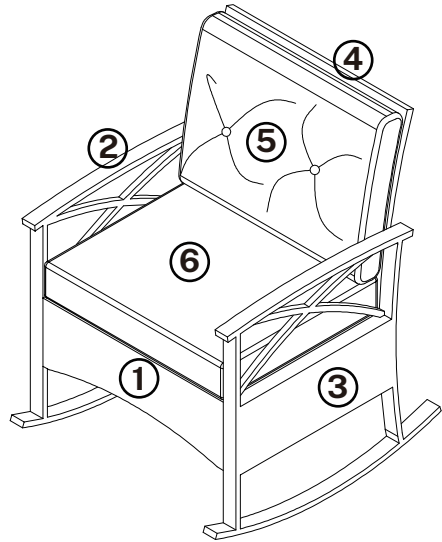

**X2**

# Safety Information

**IMPORTANT:** READ ALL INSTRUCTIONS BEFORE ASSEMBLY AND USE. FAILURE TO FOLLOW THESE INSTRUCTIONS MAY RESULT IN SERIOUS INJURY OR PROPERTY DAMAGE.

## UNDERSTANDING SAFETY SIGNAL WORDS (ANSIZ535)

### ▲DANGER:

Indicates a hazardous situation which, if not avoided, **will** result in death or serious injury.

### ▲WARNING:

Indicates a hazardous situation which, if not avoided, could result in death or serious injury.

### ▲CAUTION:

Indicates a hazardous situation which, if not avoided, could result in minor or moderate injury.

### ▲NOTICE:

Addresses practices not related to physical injury (e.g., product damage).

## ▲WARNING: GENERAL SAFETY

### • WEIGHT CAPACITY:

Max 250lbs (113kg) per chair. Table Max: 50lbs (22.7kg) distributed.  
DO NOT EXCEED THESE LIMITS.

### • TIP-OVER HAZARD:

Do not stand on armrests, backrests, or the table. Do not use the product as a step ladder or climbing structure.

### • CHILD SAFETY:

This product contains small parts which may present a choking hazard to children under 3 years of age. Keep all hardware and plastic bags away from children and pets.

### • GLASS SAFETY:

The table contains tempered glass. Although tempered glass is stronger than standard glass, it can still shatter if struck on the edge or dropped. Never sit or stand on the glass table.

# Safety Information

## ▲ CAUTION: ASSEMBLY & USE

- **PINCH POINTS:**

Keep hands and fingers clear of moving parts and connection points during assembly and while rocking.

- **STABILITY:**

Always assemble and use this product on a flat, level, and stable surface.

- **HOT SURFACES:**

Metal frames and glass can become hot in direct sunlight. Test the surface temperature before use to avoid burns.

## CARE & MAINTENANCE

- **HARDWARE CHECK:**

Screws may loosen over time. **Check and re-tighten all bolts every 2-3 months.**

- **CLEANING:**





Use mild soap and water only. Do not use bleach, sheel wool, or harsh chemicals (acetone, ammonia).

- **WEATHER:**

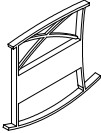

Store cushion indoors when not in use. Use a breathable furniture cover if leaving the frame outdoors for extended periods.

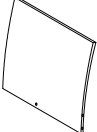
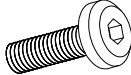
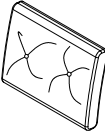
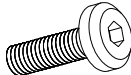
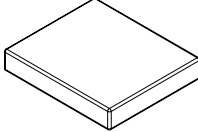
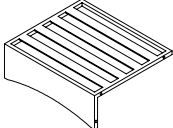
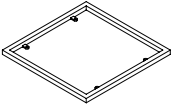
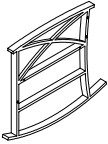
# Part List & Hardware

**NOTE:** The quantities below represent the parts required for the **ENTIRE SET** (2 Chairs + 1 Table).

Item no.	Reference Image	Qty.	Item no.	Reference Image	Qty.
<b>A</b>	 Allen key	<b>1</b>	<b>3</b>	 Left Arm Frame	<b>2</b>
<b>B</b>	 Washer M6	<b>34</b>	<b>4</b>	 Backrest Panel	<b>2</b>
<b>C</b>	 Screw M6*15mm (Short)	<b>12</b>	<b>5</b>	 Seat Cushion	<b>2</b>
<b>D</b>	 Screw M6*35mm (Long)	<b>22</b>	<b>6</b>	 Back Cushion	<b>2</b>
<b>1</b>	 Seat Panel	<b>2</b>	<b>7</b>	 Table Top Frame	<b>1</b>
<b>2</b>	 Right Arm Frame	<b>2</b>	<b>8</b>	 Table Legs	<b>4</b>

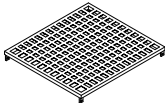
# Part List & Hardware

Item no.	Reference Image	Qty.	Item no.	Reference Image	Qty.
9	 Shelf Frame	1	10	 Glass Top	1

## BEFORE YOU START

1. Work on a clean, flat, and level surface.
2. Confirm all listed parts and hardware are present.
3. Use only the included Allen key. Do not use a power drill.
4. Two-Stage Screw Tightening:
  - a. Initial Fit: Align all parts and tighten screws until snug (about 50%).
  - b. Final Tightening: Once assembly is complete and correctly aligned, fully tighten all screws.
5. If parts do not align easily, slightly loosen nearby screws, adjust the position, and then retighten.

# Installation Steps

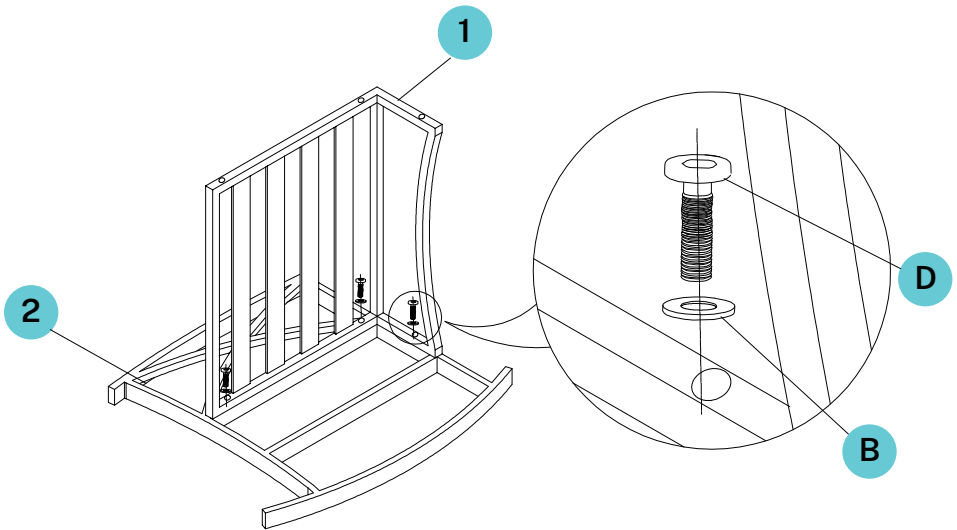
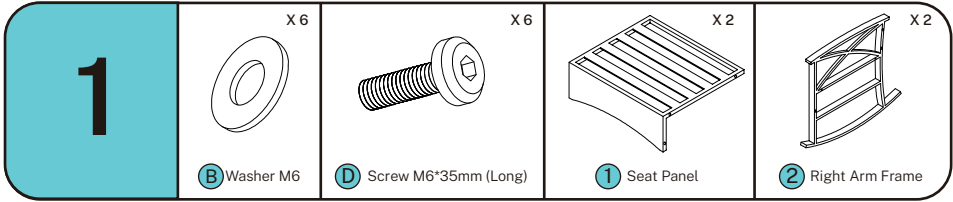

X 2



## STEP 1: Connect Seat to Right Arm

Align the **Seat Panel (Part 1)** with the mounting holes on the **Right Arm Frame (Part 2)**. Insert **Washer (Part B)** and **Screw (Part D)**.

**NOTICE:** Tighten to **50% only**.

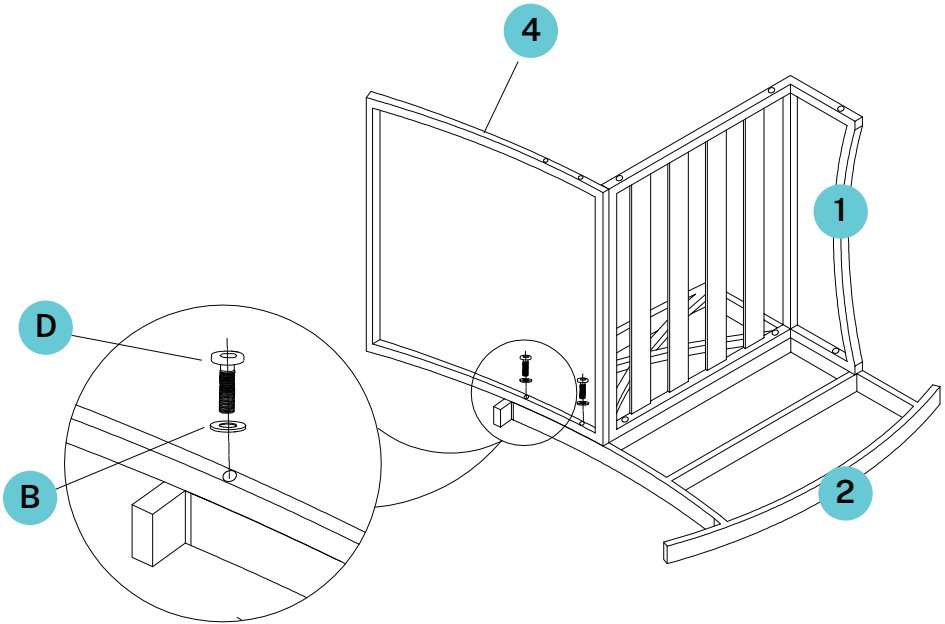
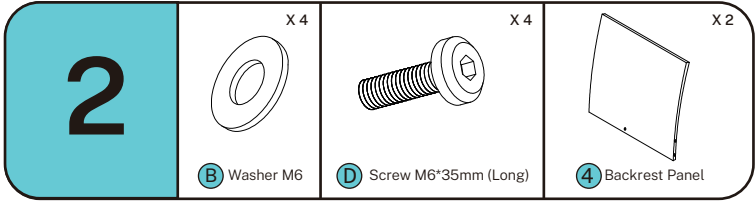

X 2

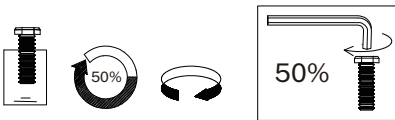

## STEP 2: Connect Backrest

Attach the **Backrest Panel (Part 4)** to the rear of the **Right Arm Frame (Part 2)** using **Washer (Part B)** and **Screw (Part D)**.

**NOTICE:** Tighten to **50%** only.

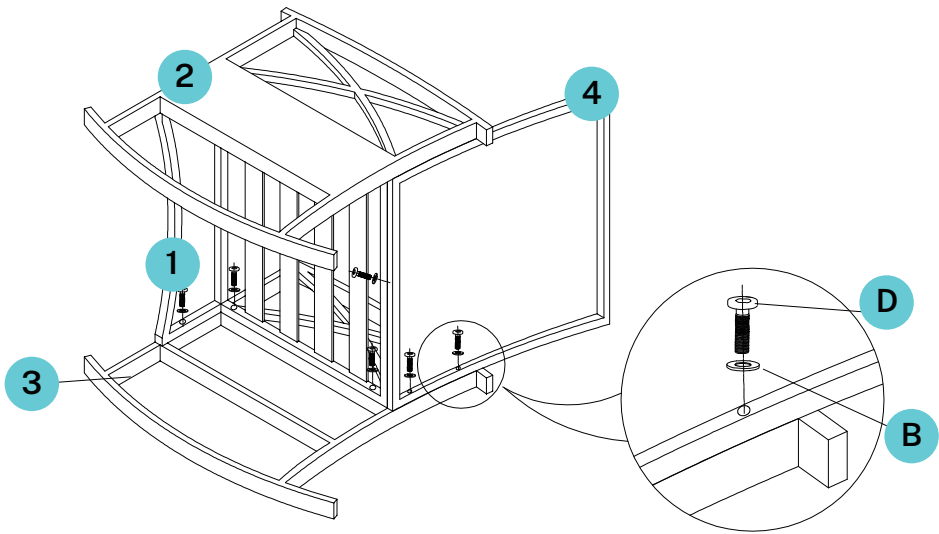
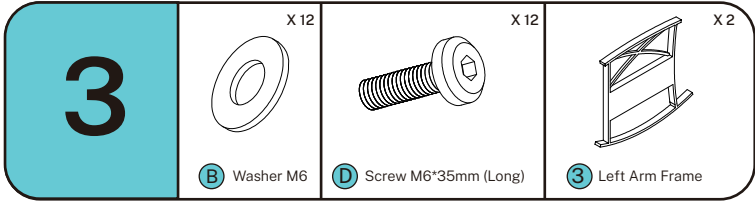

X 2



### STEP 3: Attach Left Arm

Align the **Left Arm Frame (Part 3)** with the **Seat Cushion (Part 5)** and **Backrest Panel (Part 4)** assembly. Secure all connection points using **Washer (Part B)** and **Screw (Part D)**.

**NOTICE:** Tighten to **50% only**.

4

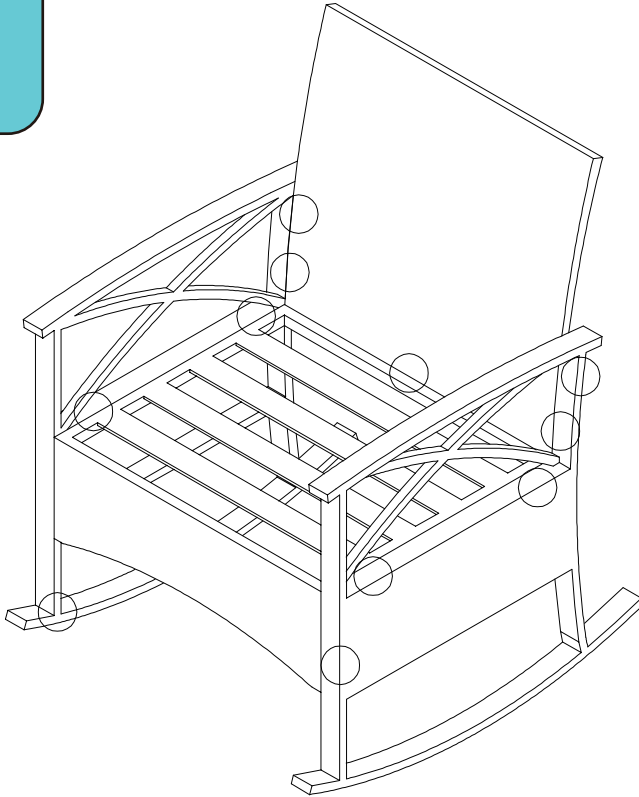

X 2

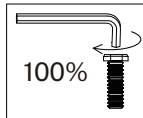
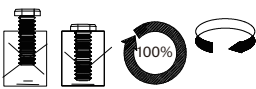

#### STEP 4: Tightening

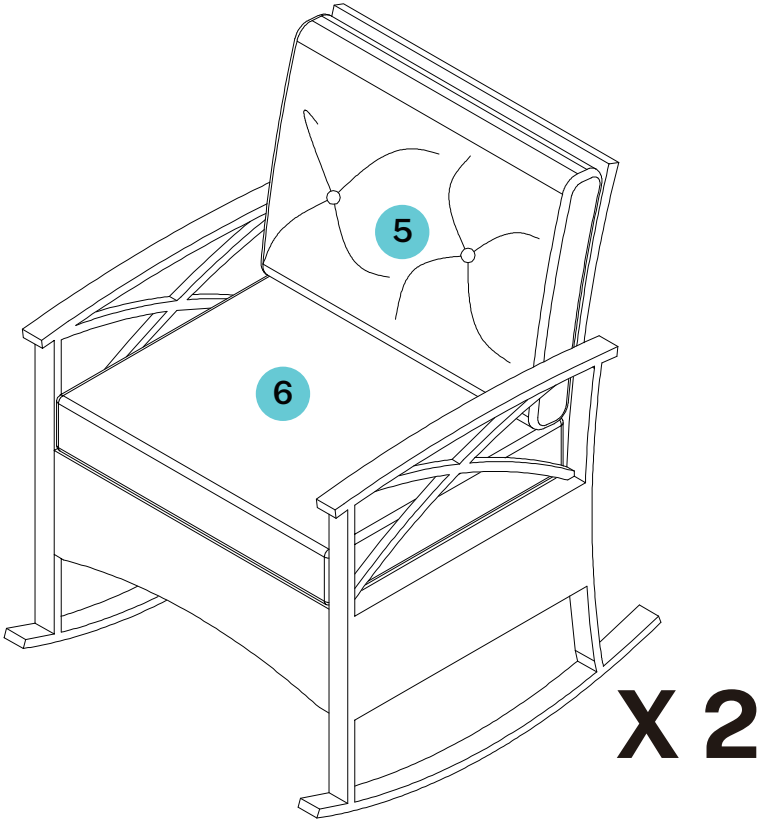
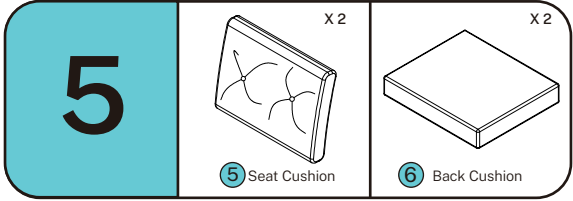

Place the chair upright on a flat surface.  
Adjust the frame so it sits level on the floor.

**NOTICE: BRUTE FORCE RISK.** Using the Allen key, tighten all screws to 100%. **Do not over-tighten.** Stop immediately when you feel firm resistance. Over-tightening can strip the internal threads.

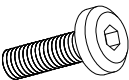
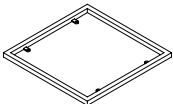

**STEP 5: Final Cushions**

Place **Seat Cushion (Part 5)** and **Back Cushion (Part 6)** onto the frame.

6	X 8	X 8	X 1	X 4
	 <b>B</b> Washer M6	 <b>C</b> Screw M6*15mm (Short)	 <b>7</b> Table Top Frame	 <b>8</b> Table Legs

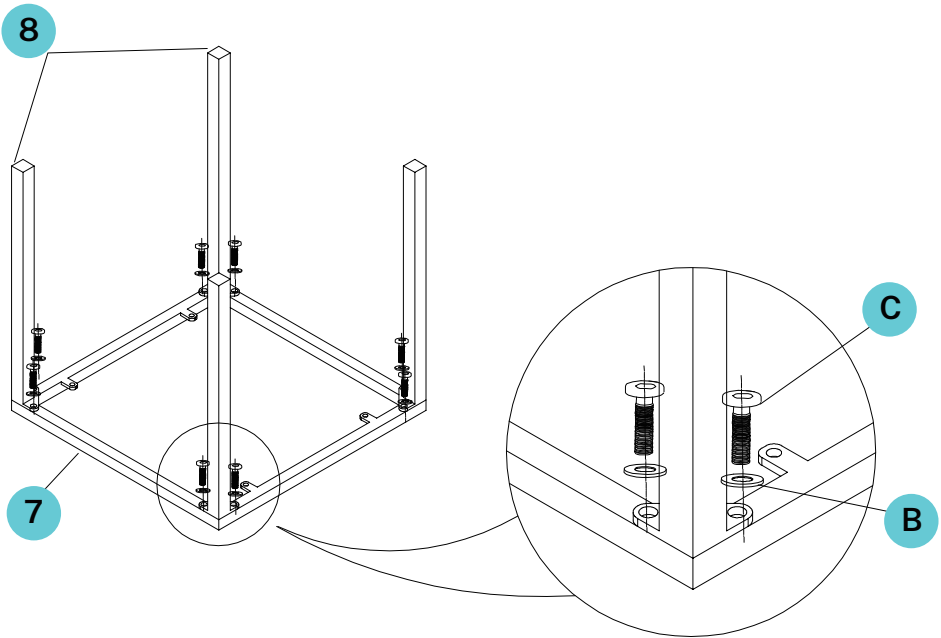

## STEP 6: Attach Legs to Top Frame

Place the **Table Top Frame (Part 7)** upside down on a soft surface. Attach the four **Table Legs (Part 8)** using **Washer (Part B)** and **Screw (Part C)**.

**NOTICE:** Tighten to **50%** only.

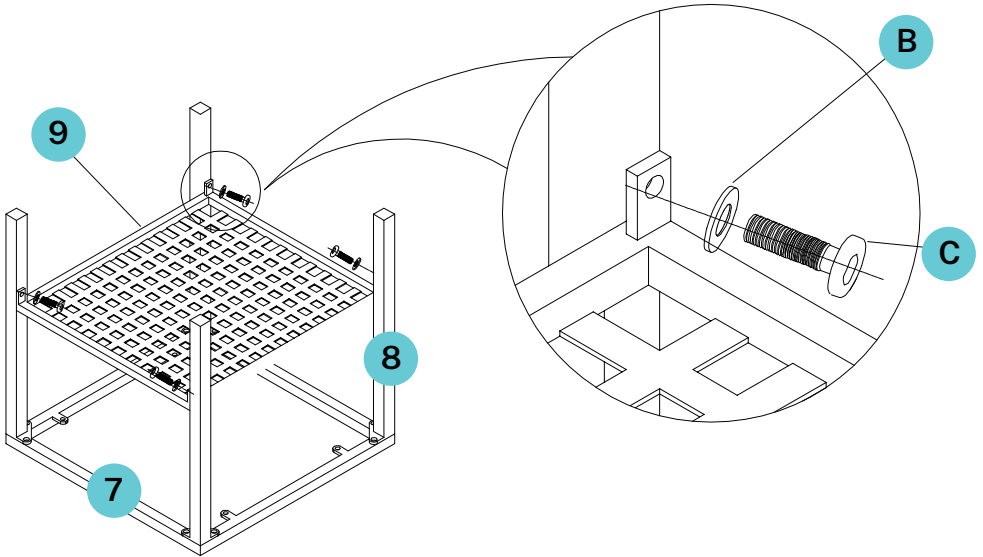
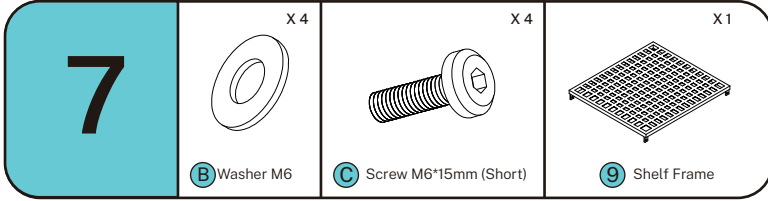

## STEP 7: Attach Shelf

Fit the **Shelf Frame (Part 9)** between the four legs. Secure using **Washer (Part B)** and **Screw (Part C)**.

**NOTICE:** Tighten to **50% only**.

8

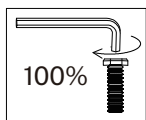
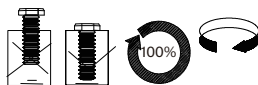
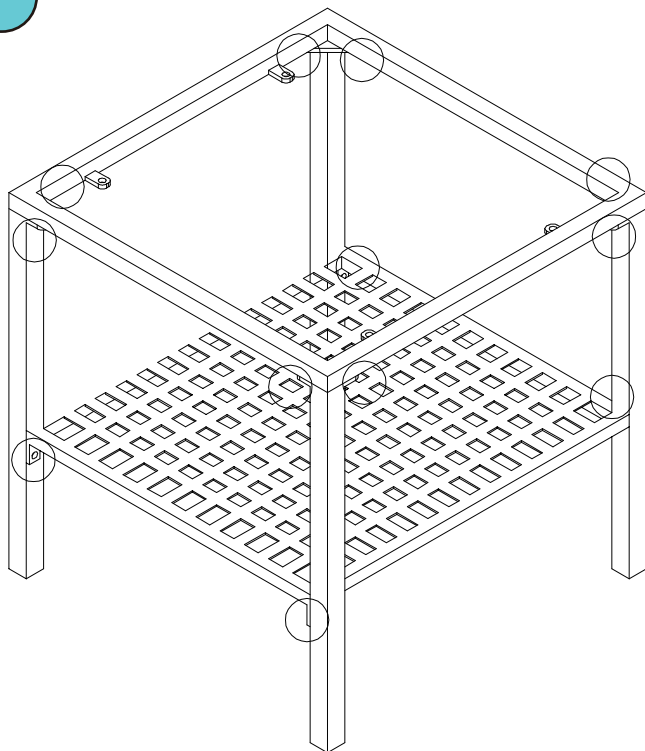

## STEP 8: Final Tightening

Ensure the table legs are aligned.

**Notice:** Tighten all screws to 100%. **Do not over-tighten.**

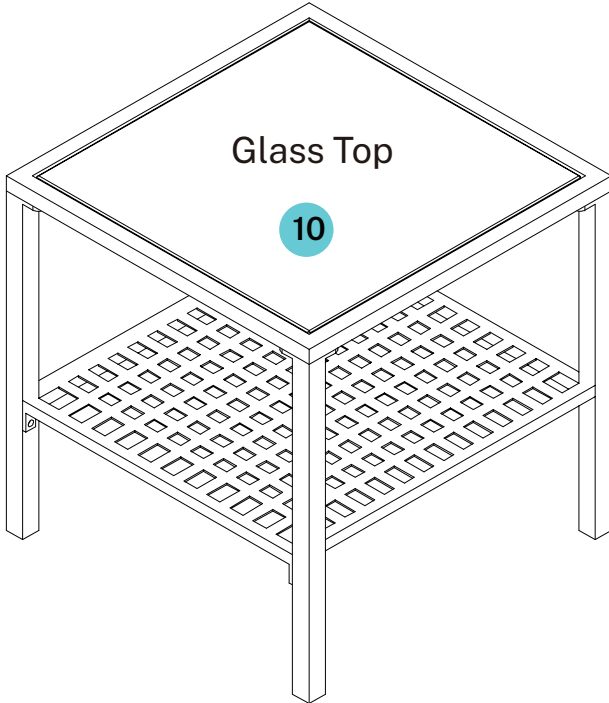
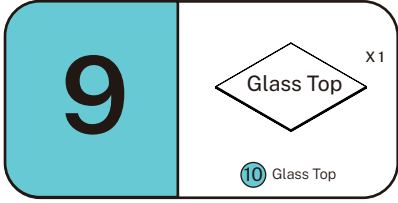

### STEP 9: Insert Glass Top

Ensure that the table is facing upwards. Carefully place the **Glass Top (Part 10)** into the recess of the Table Top Frame.

**▲ WARNING: FORCE RISK DO NOT FORCE THE GLASS.** If the glass does not fit easily, the frame is likely skewed. Loosen the frame screws slightly, adjust the frame squareness, and re-tighten before placing the glass. Forcing the glass into a skewed frame may cause it to shatter, resulting in injury.

**ASSEMBLY COMPLETE** Enjoy your new furniture set. *Retain this manual for future reference.*