

Papros

Model: FFLWM010BK FFLWM010NL FFLWM010WE

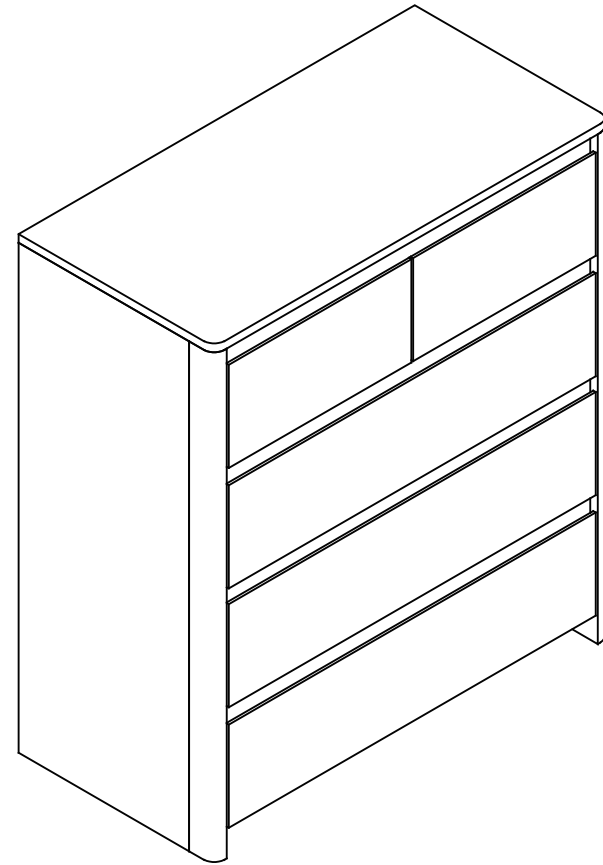

info@serviceprohelp.com

PLEASE READ CAREFULLY

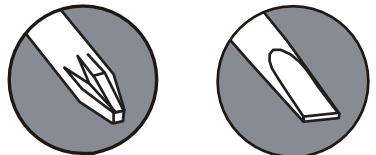

TOOLS REQUIRED



Move this piece of furniture gently with two people.



Two people are required for assembly.



Read this assembly manual carefully, and verify that you have all the parts listed before you begin. Keep your assembly manual for future reference.



Do not place very hot/cold objects on top of any surface. Always use a coaster or mat. Never leave liquids on the surface: Clean immediately with a mild soap and a damp cloth. Never use scouring powder based cleanser.



Protect finishes by placing furniture pieces on a soft carpeted surface during assembly.



SAFE INFORMATION

WARNING: To prevent serious injury or death from furniture tip-overs.

- **NEVER** allow children to climb, stand, or play on any furniture.
- **ALWAYS** supervise children around furniture.
- **KEEP** remote controls, toys, and other attractive items out of reach from the tops of furniture.

WARNING: ALWAYS anchor furniture to the wall.

- **Anchoring is ESSENTIAL** to prevent tip-overs.
- **Anchor DIRECTLY** to wall studs or masonry using appropriate hardware.
- **CONSULT** a qualified professional if you are uncertain about your wall construction or how to install anchors properly.
- **REFER** to your television and furniture owner's manuals for model-specific instructions.
- **NEVER** remove wall anchors without first emptying all items from the furniture.

CAUTION: Use only furniture designed for **TVs**.

- **Placing a TV** on furniture **NOT** designed for it (e.g., dressers, bookcases) creates a top-heavy, unstable hazard.
- **USE ONLY** furniture specifically designed and rated to support the weight and size of your television.
- **FOLLOW** all manufacturer instructions for installation and weight limits.

For more details, visit <https://www.anchorit.gov/>

EXPLODED VIEW

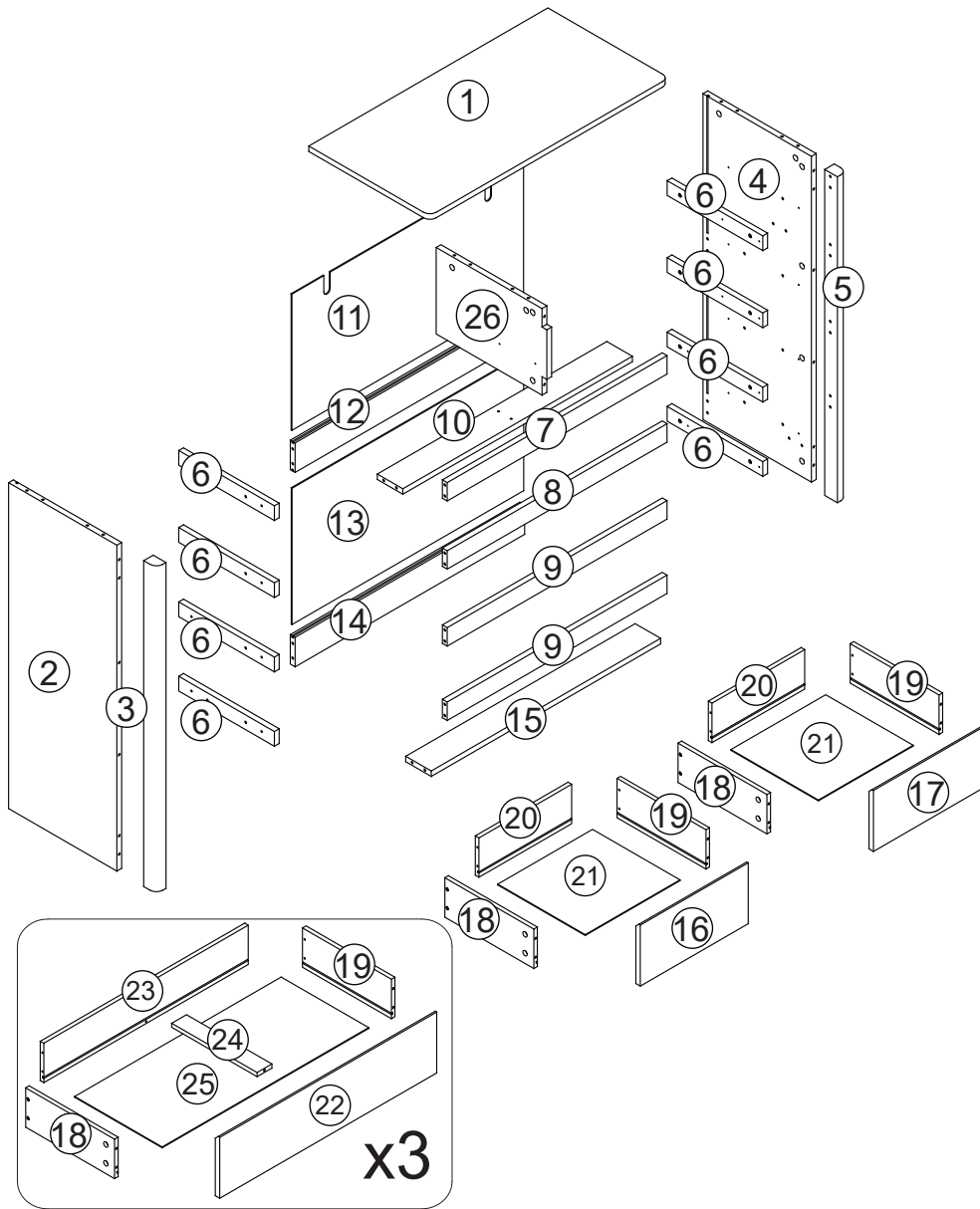

4

PARTS

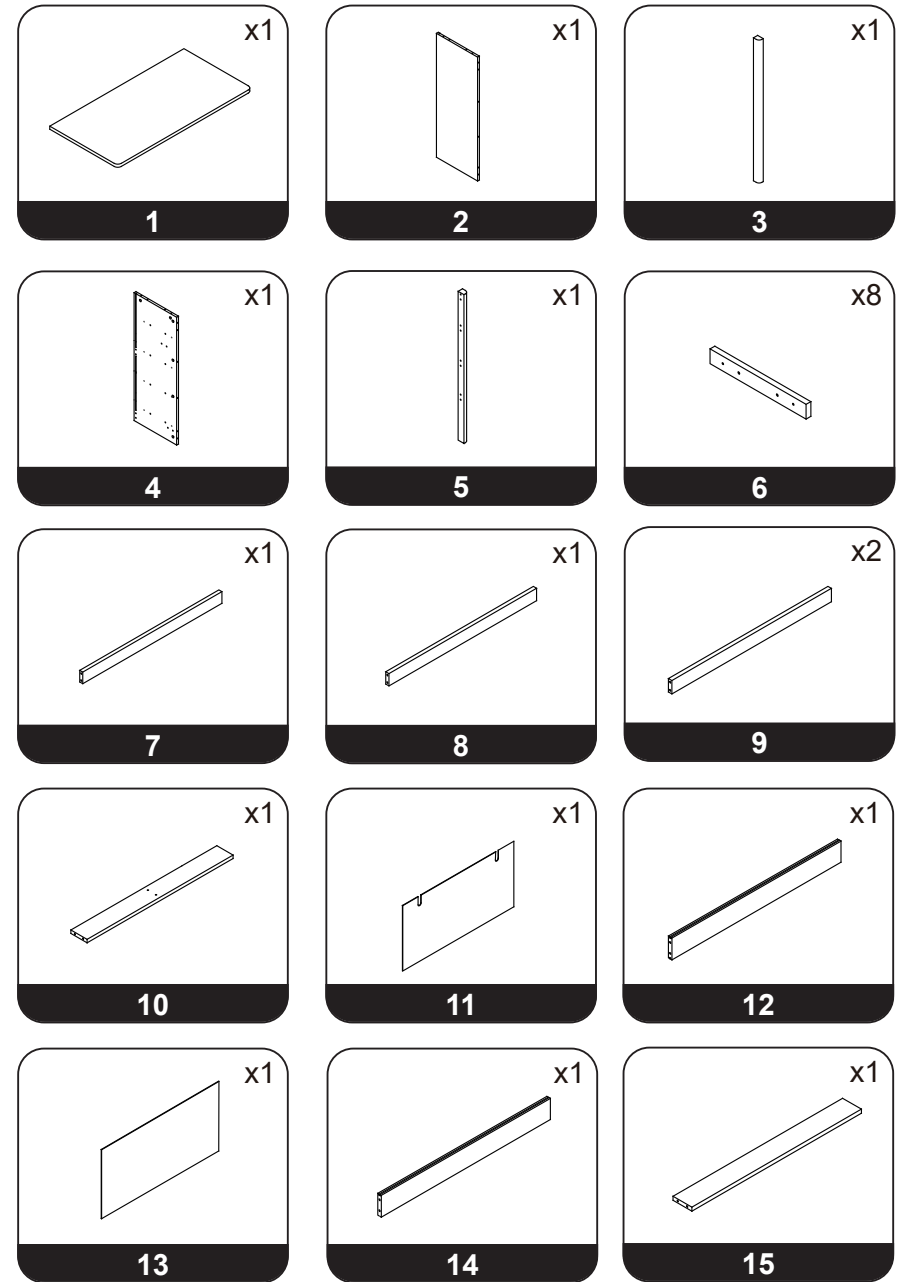

5

PARTS

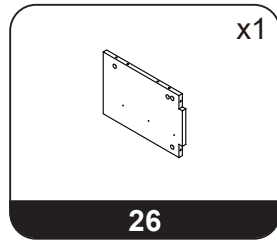
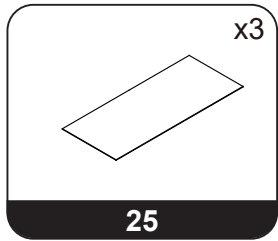
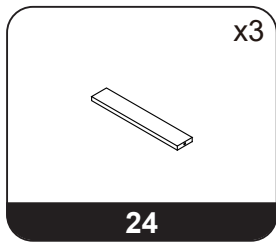
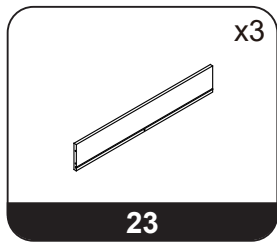
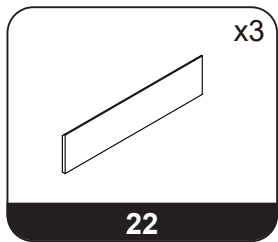
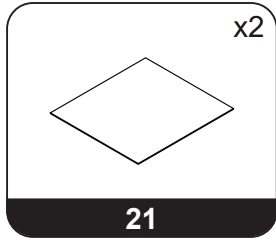
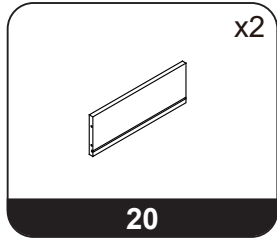
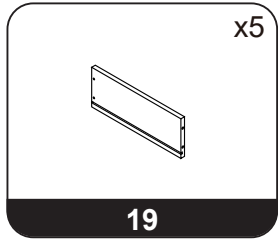
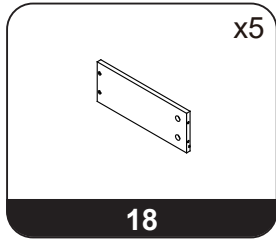
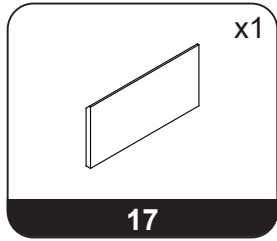
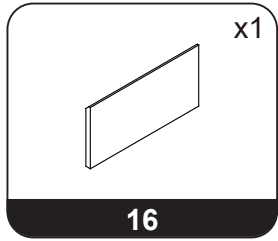

HARDWARE

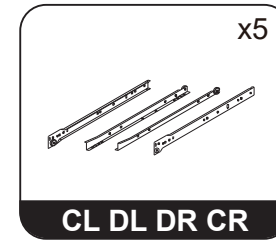
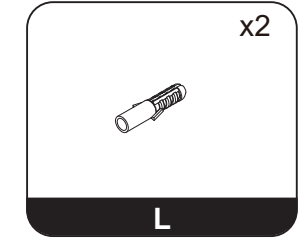
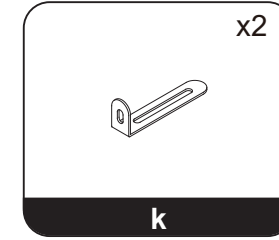
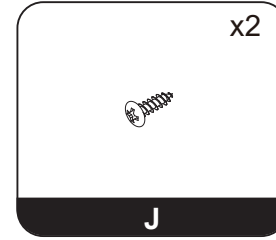
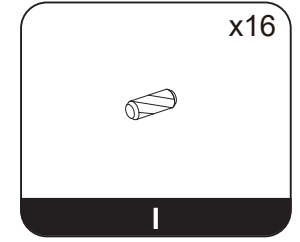
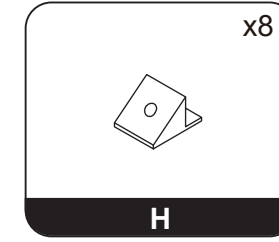
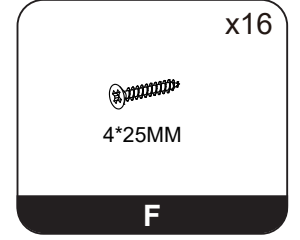
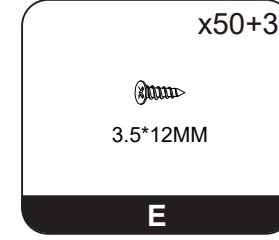
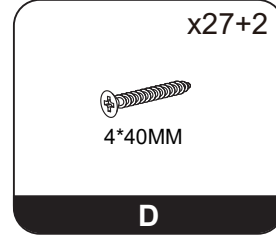
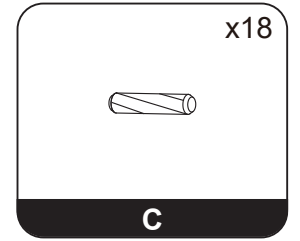
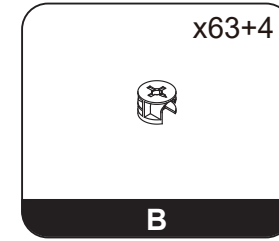
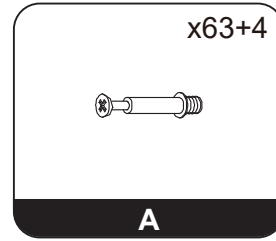

ASSEMBLY INSTRUCTIONS



Do not tighten the screws until all of them are fastened into the holes.

STEP 1

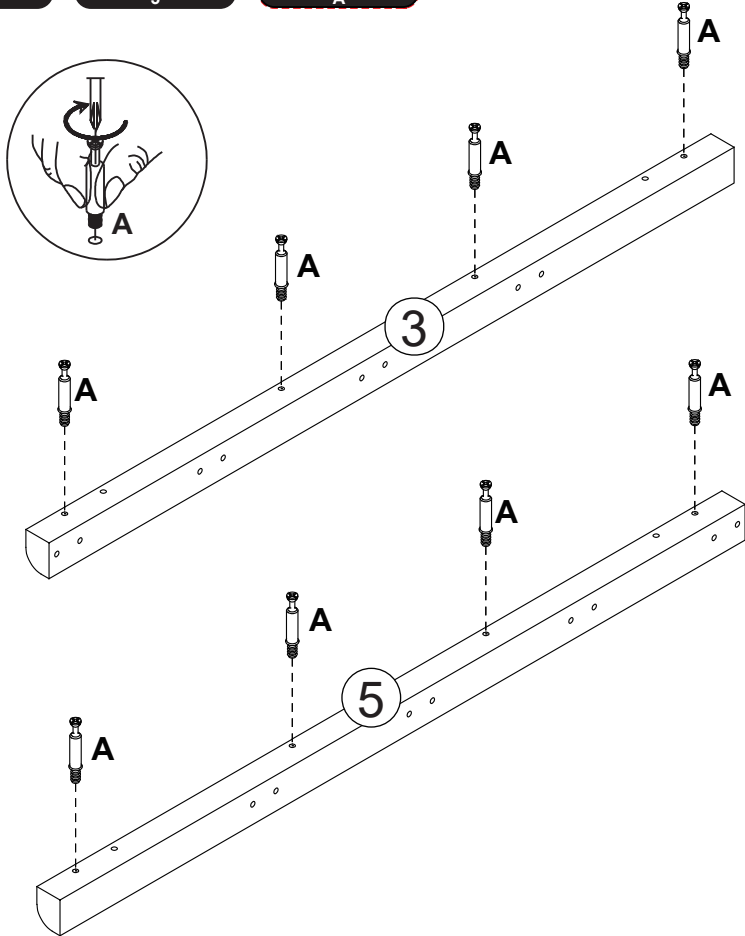
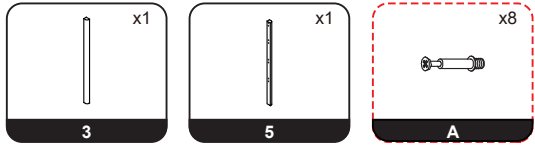

8

STEP 2

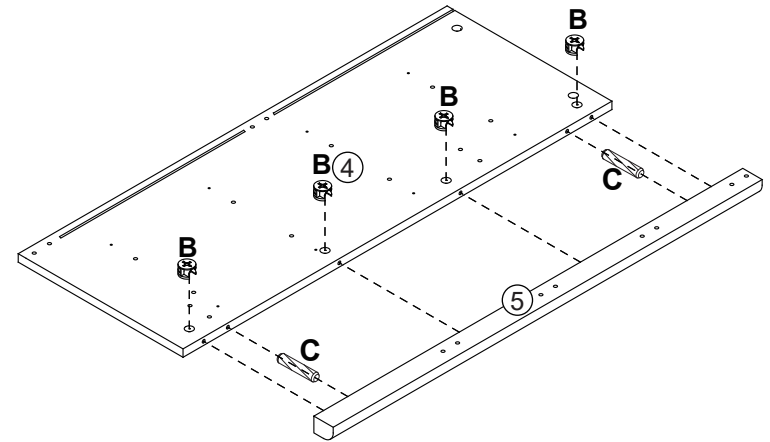
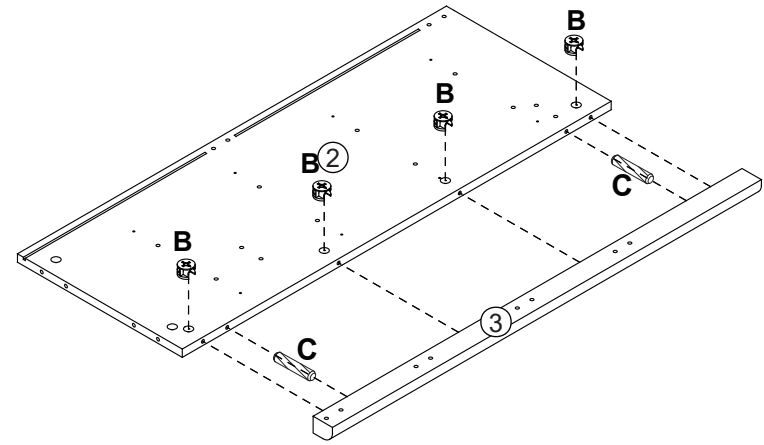
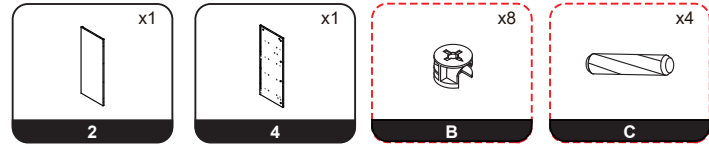

9

STEP 5

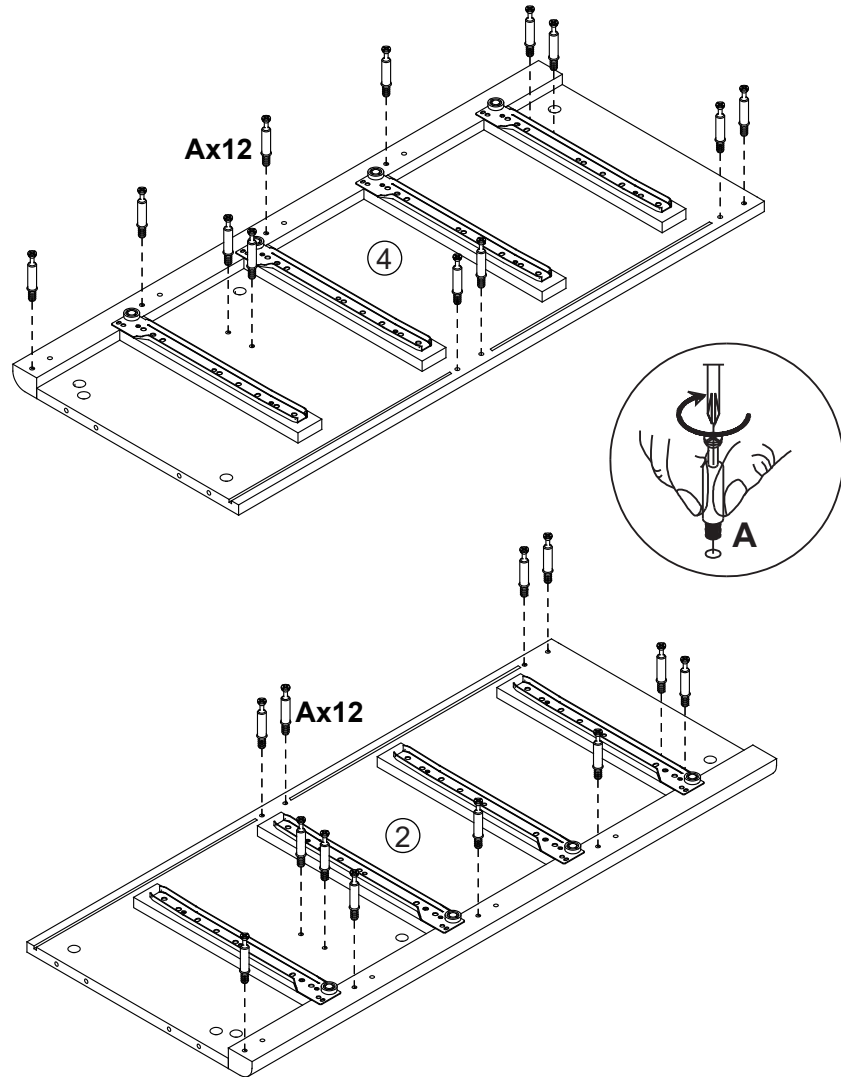
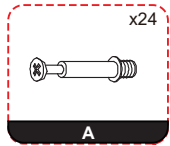

12

STEP 6

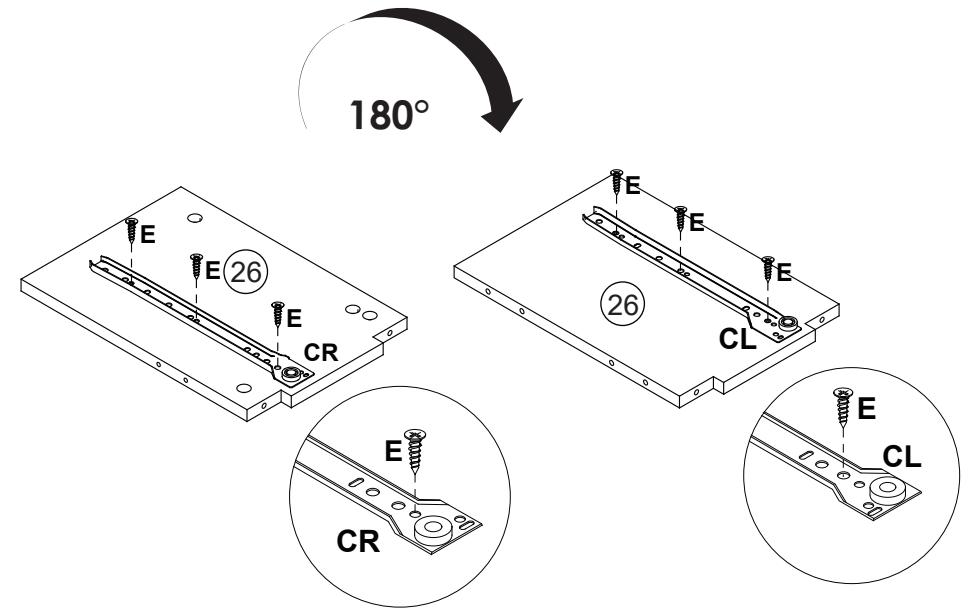
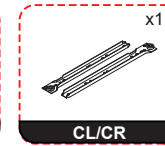
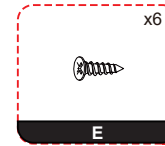
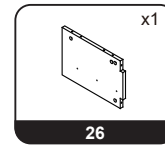

13

STEP 7

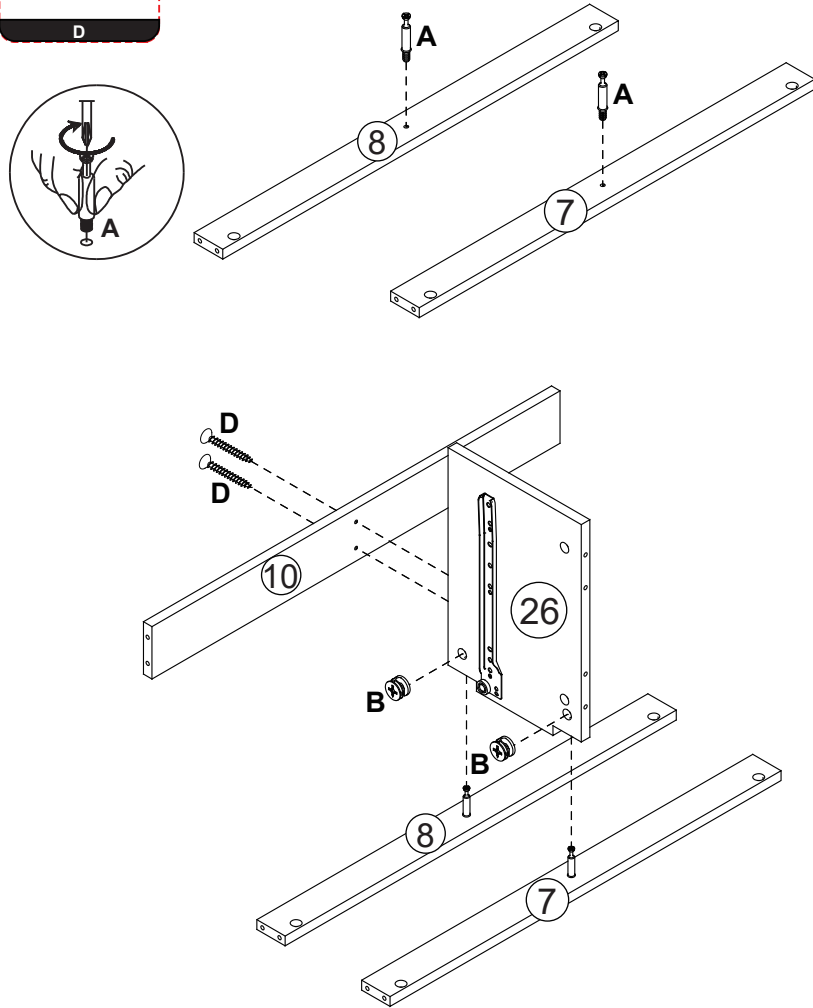
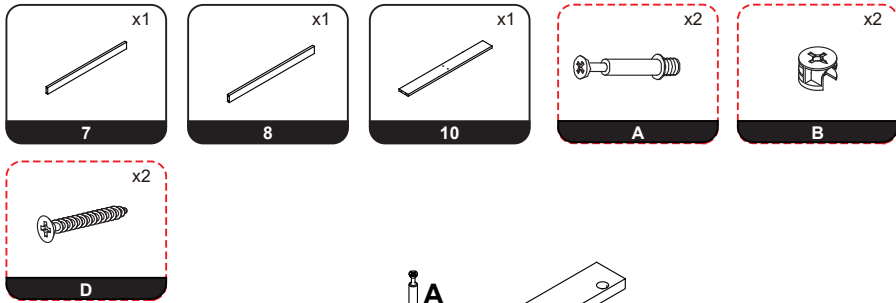

STEP 8

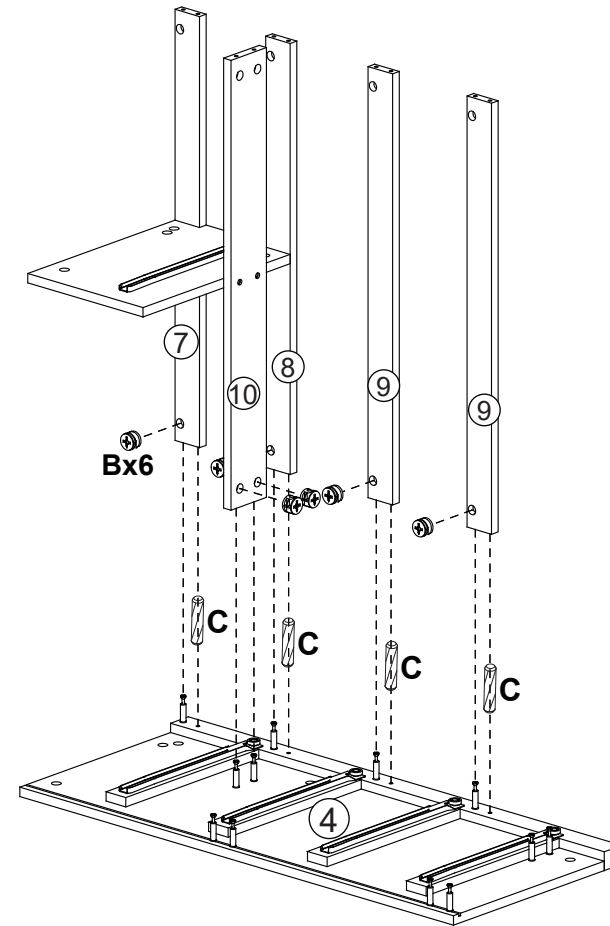
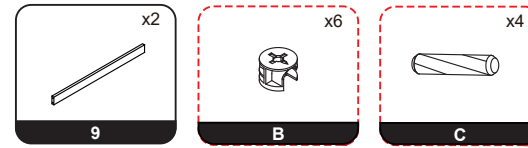

STEP 9

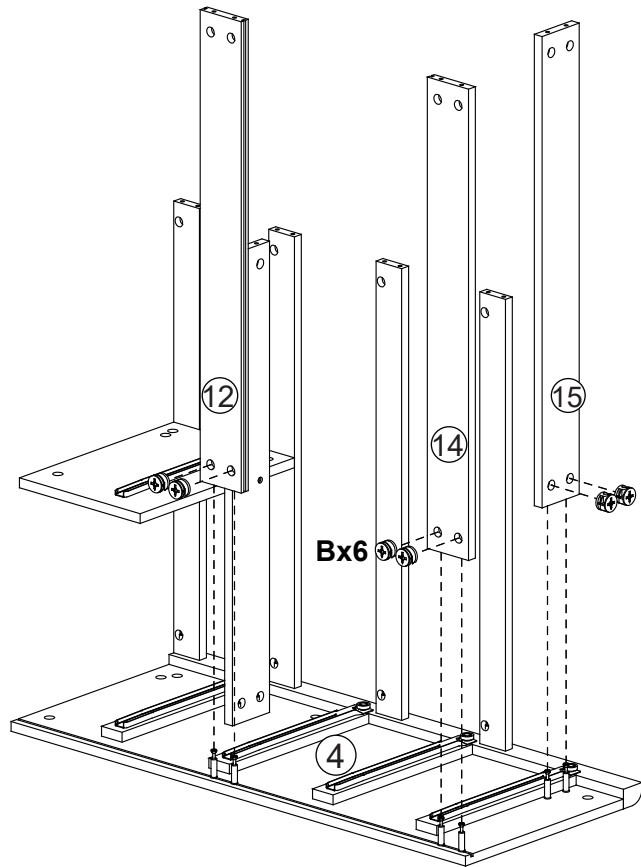
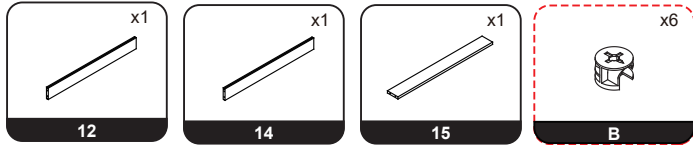

16

STEP 10

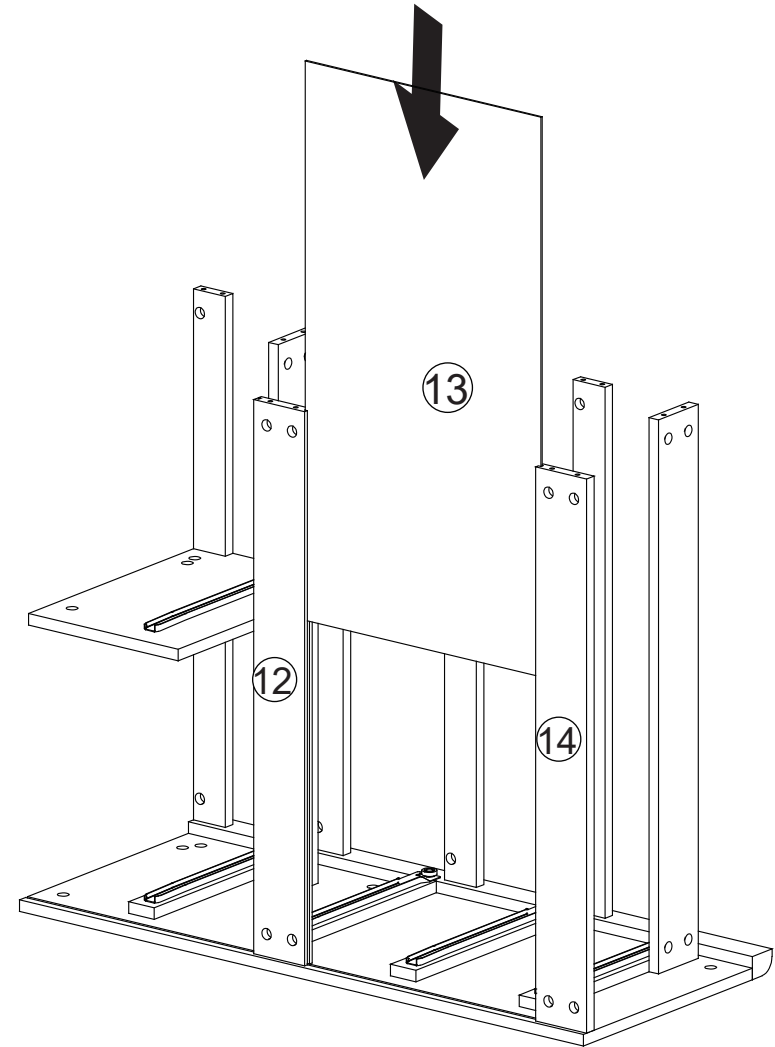
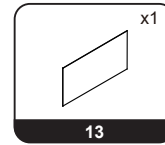

17

STEP 11

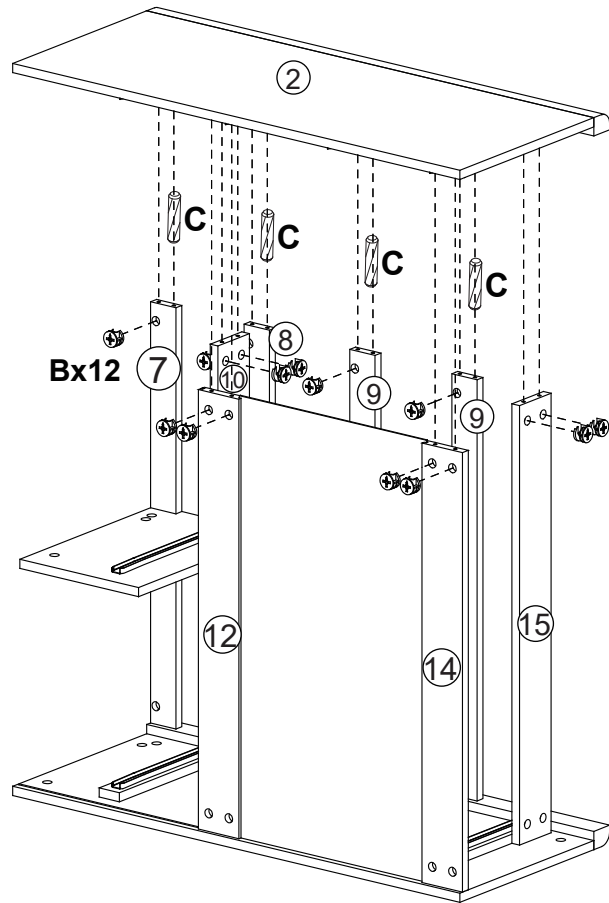
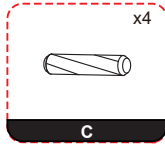
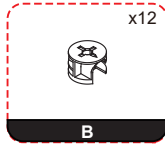
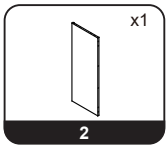

18

STEP 12

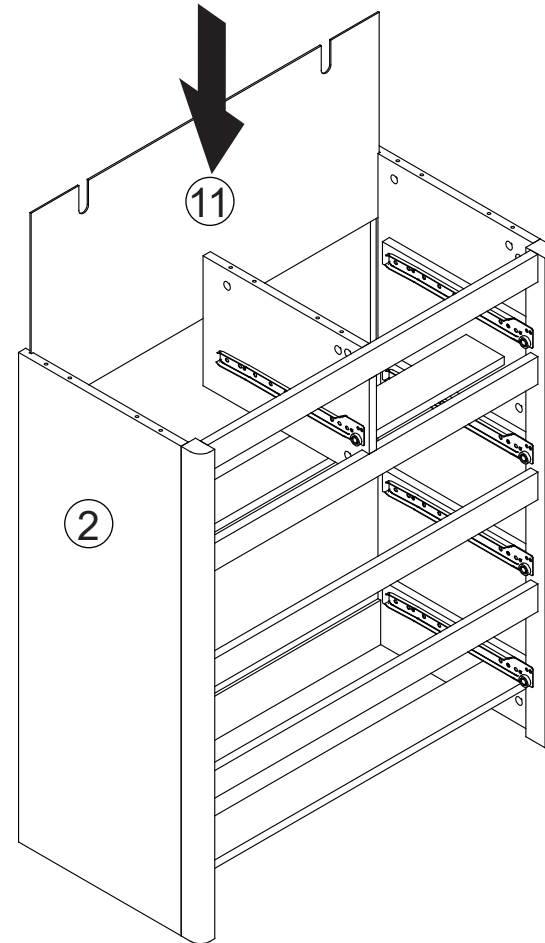
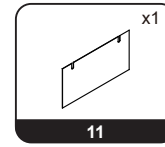

19

STEP 13

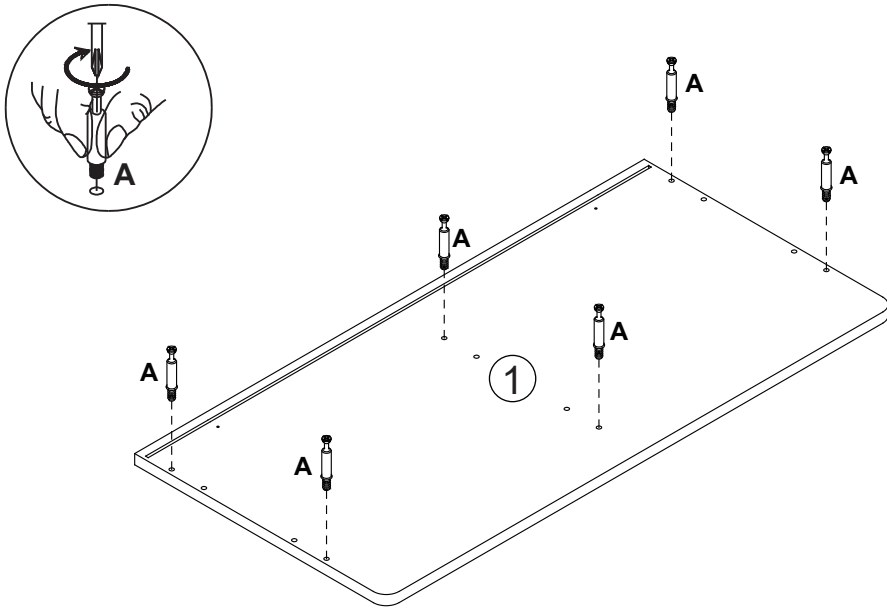
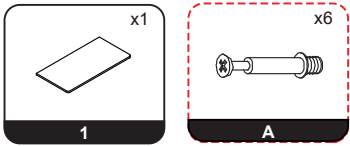

STEP 14

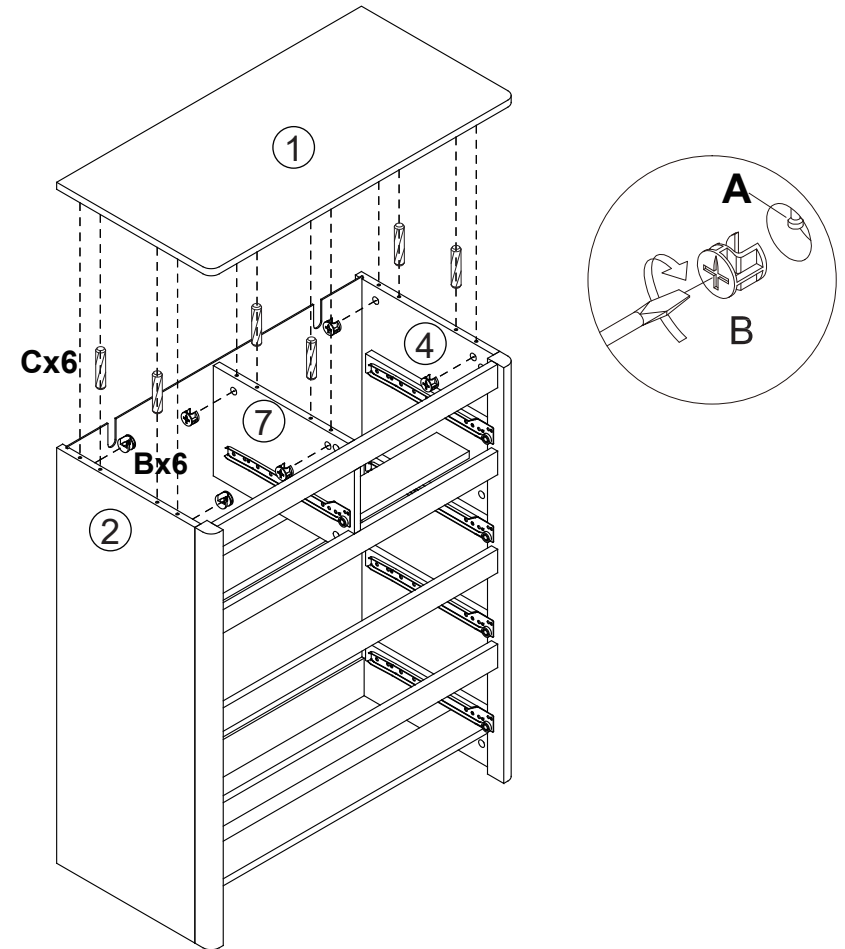
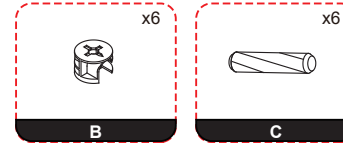

STEP 15

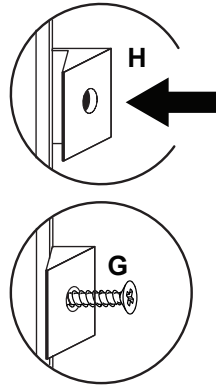
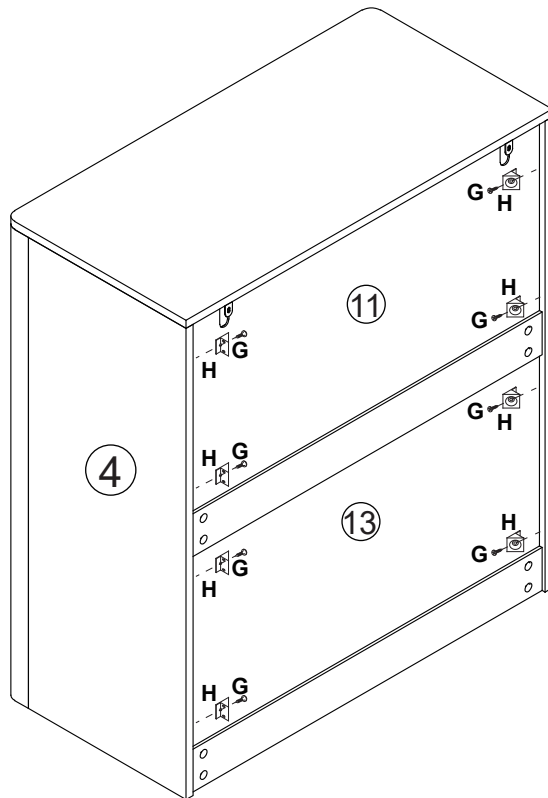
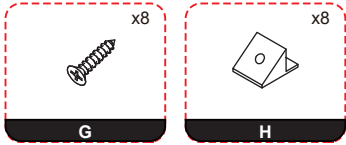

STEP 16

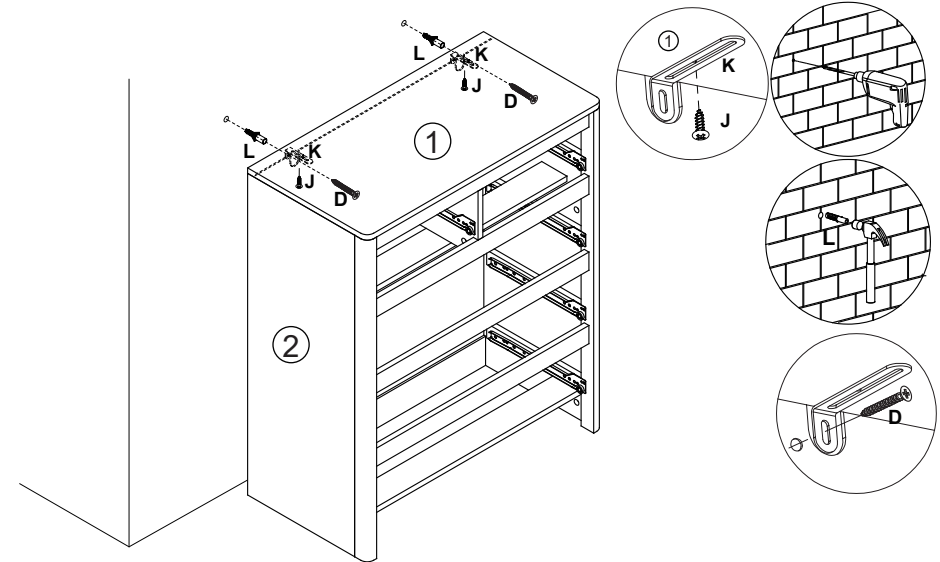
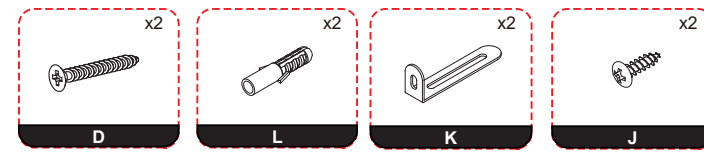

Wall Mounting Instructions

! CAUTION - Risk of Furniture Tip-Over. Always anchor this furniture securely to the wall.

- Using the screws provided and a screwdriver, secure the mounting plate(s) to the back of the product.
- Noting the location of the product's mounting plate(s), mark the corresponding positions on the wall for the wall-mounted plate(s).

Drill pilot holes at the marked locations into a wall stud.

NOTE: If wall studs are not available, drill holes slightly smaller than the drywall anchors, insert each anchor until its flange is flush with the wall.

- Using a screwdriver, secure the mounting bracket(s) to the wall stud or to the drywall anchors using the screws provided.
- Position the product in its final location. Lace one end of the plastic tie(s) through both the wall-mounted plate and the product's mounting plate, then loop through the other end. Pull the tie(s) tight to remove slack. Do not overtighten.

STEP 17

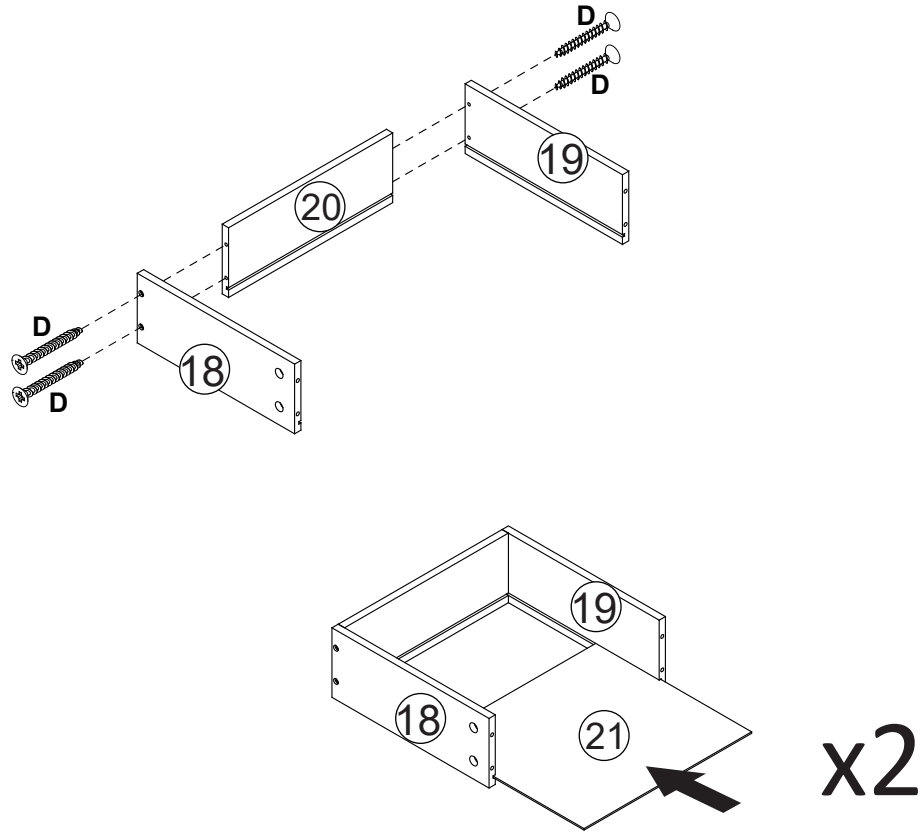
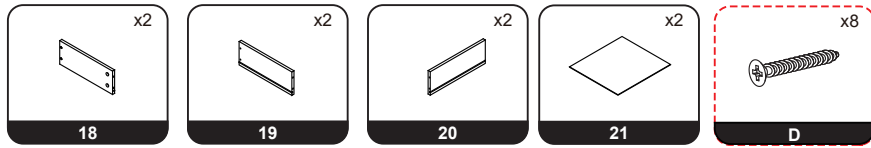

24

STEP 18

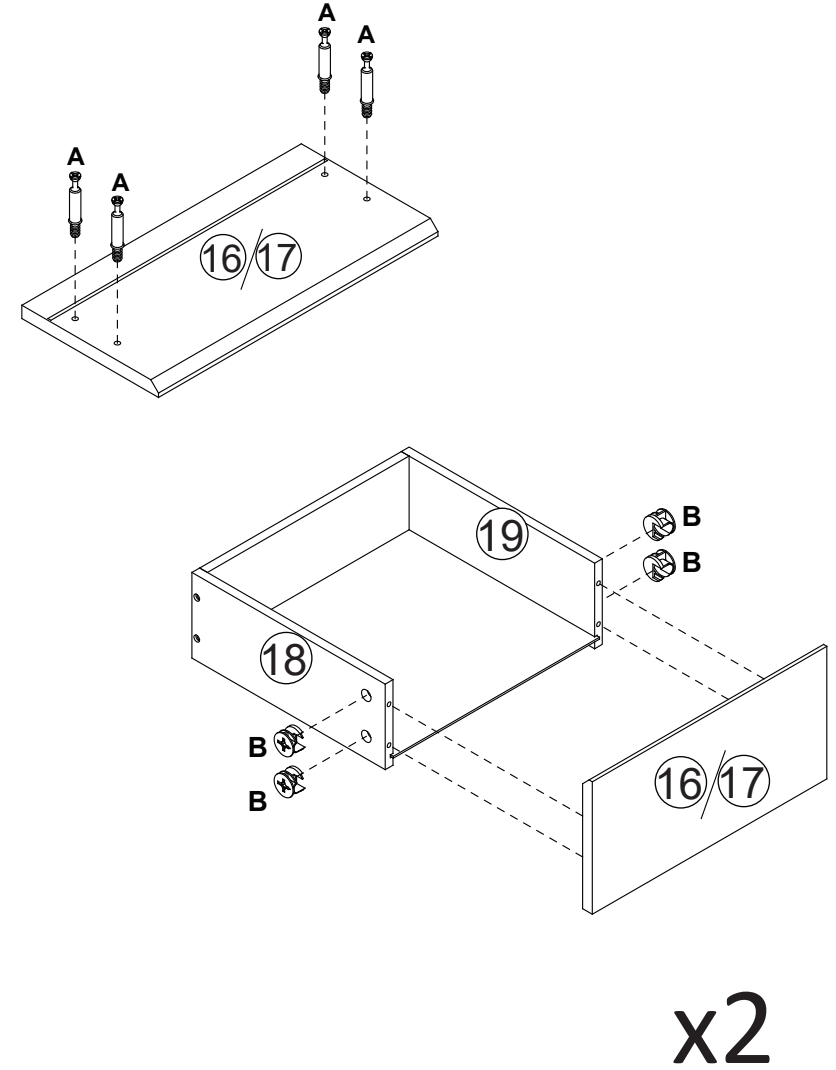
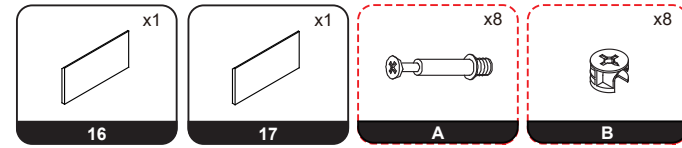

25

STEP 19

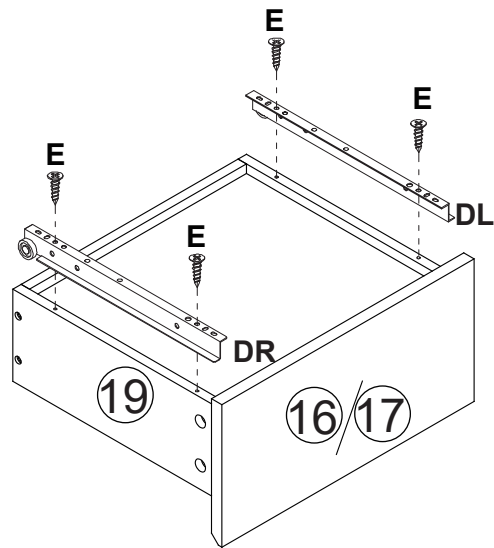
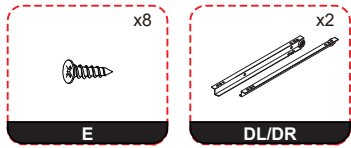

x2

26

STEP 20

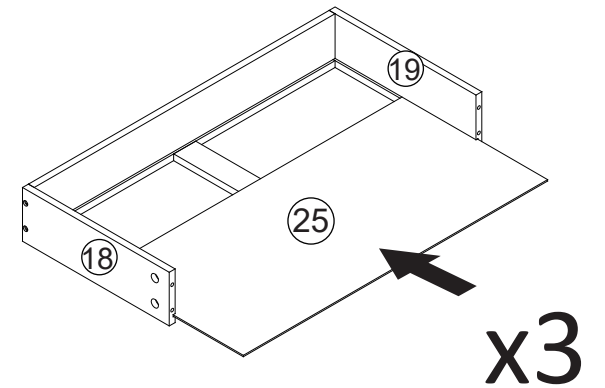
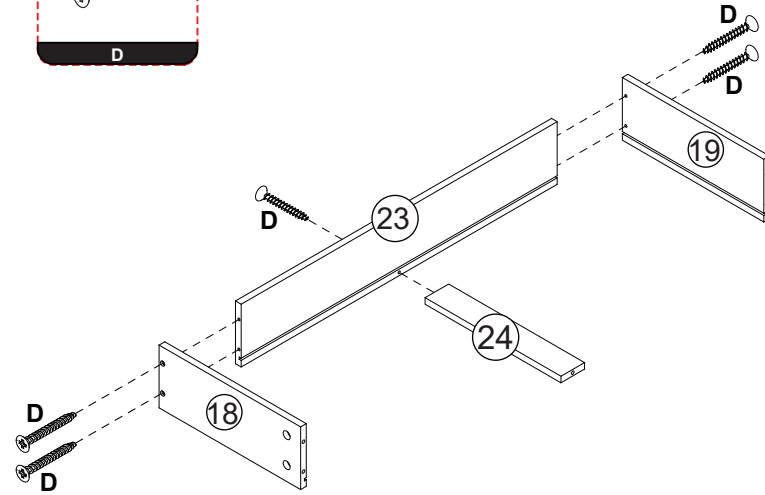
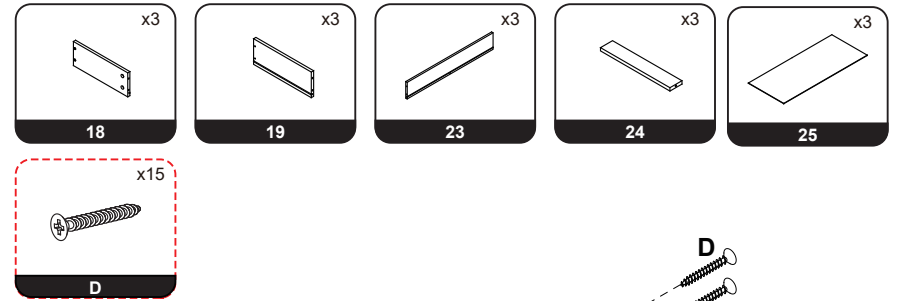

27

STEP 21

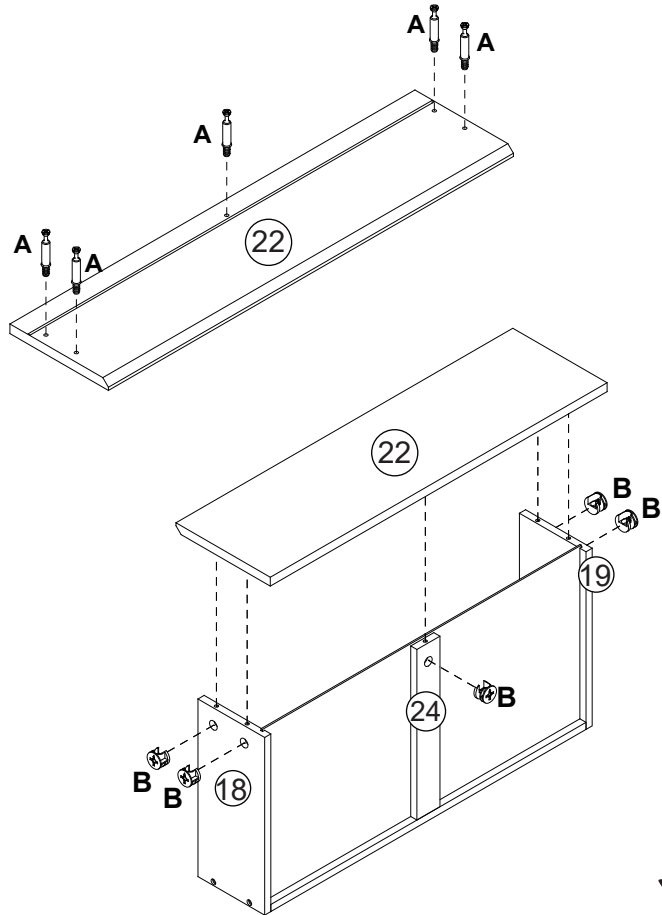
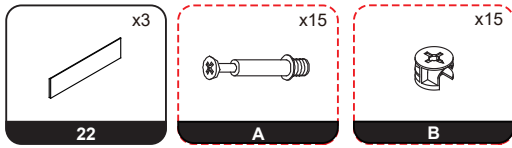

28

STEP 22

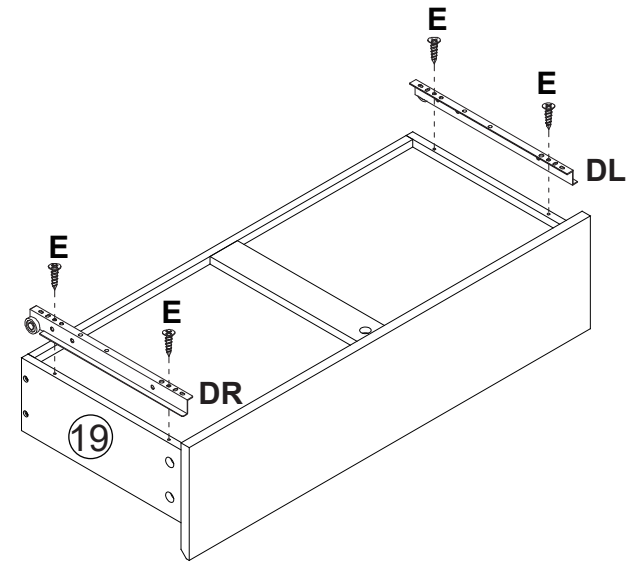
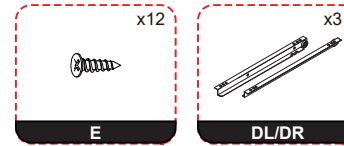

x3

29

STEP 23

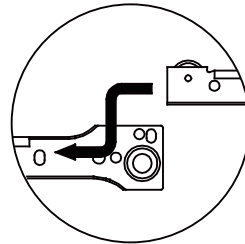
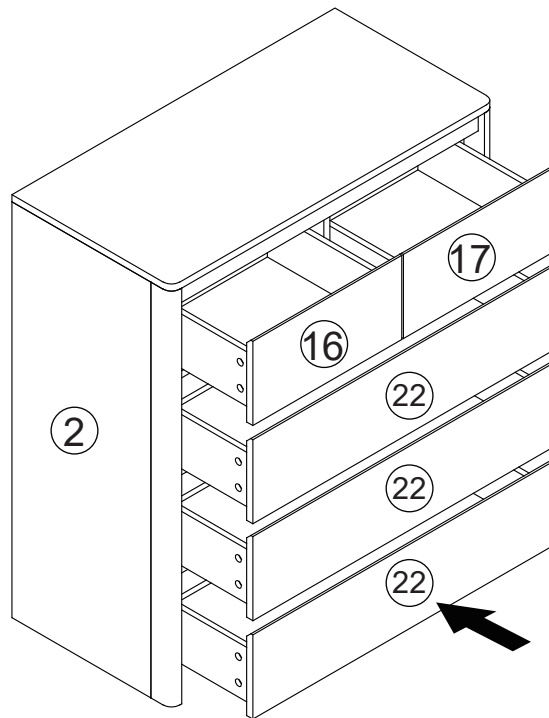

MAINTENANCE

- Wipe the surface with a soft, damp cloth and dry immediately.
- Avoid using chemical cleaners, solvents, or abrasive pads that could damage the finish.
- Do not place hot, wet, or heavy items directly on the surface.
- Keep the furniture away from direct sunlight and excessive humidity to prevent warping or discoloration.
- Check and tighten all screws periodically to maintain stability.

Warranty & Support

Limited Warranty

This product is backed by a limited warranty that covers manufacturing defects under normal household use.

Customer Service

If you have received a damaged product or are missing parts, please contact us directly for assistance. Do not return the product to the store.

When contacting us, please provide the following information:

- Order number or proof of purchase
- Clear photos showing the issue or damaged parts
- Product model number (as listed in this manual)

Email: info@serviceprohelp.com

We will respond promptly with instructions for replacement parts or other solutions.

Thank you for choosing our product. Enjoy your new furniture!